



ATTENTION : Consult the operating instructions before using the equipment.
If these precautions are not properly observed and carried out, it can cause physical accident or damage to the equipment or the installation.
The manufacturer or the authorized seller is not responsible for the consequences resulting from failure to comply with these precautions.

SAFETY PRECAUTIONS

This equipment has been manufactured and tested and it has left the factory in perfectly safe condition. To preserve this and ensure safe operation of the equipment the user should comply with the instructions which are mentioned in this manual.

Before installing, check that the operating and network voltages are the same!

Before carrying out any work on the equipment, check that it is disconnected from the electrical supply.

If the equipment is no longer completely safe to use, it should be taken out of service and protected against any accidental use.

Operator Safety

Read the following recommendations carefully before installing and operating the equipment.

The equipment described in this manual is designed only to be used by trained personnel.

Maintenance work must be carried out only by qualified, authorised personnel.

Personnel must observe the usual safety procedures for safe operation and during any maintenance work.

Breakdown Precautions

If you suspect that the equipment may no longer be safe (e.g. because of transport or operational damage), it must be taken out of service and protected against any accidental use.

The equipment should be handed over to authorised technicians for checking.

Cleaning Instructions

Disconnect the equipment from the electrical supply and only use a damp cloth to clean the external surfaces.

Do not use any abrasive materials or solvents. Do not allow any moisture to reach the connection terminals.

Standards which are applied to the device:

EN 61000-6-2, EN 61000-6-4, EN 55016-2-1, EN 55016-2-3, EN 55011, EN 61000-3-2, EN 61000-3-3, EN 61010-1
 EN 61000-4-2, EN 61000-4-3, EN 61000-4-4, EN 61000-4-5, EN 61000-4-6, EN 61000-4-8, EN 61000-4-11

Important note for system connection

① ② ③ indicators indicate the existence of the three phases. (See Figure 1)

If Δ indicator (**Phase sequence is not correct**) is seen, you have to change any of the 2 phases before proceeding. (L1 - L2, L2 - L3 or L1 - L3)

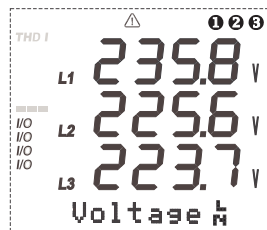

Figure 1: The existence of three phases on LCD.

SUMMARY

SAFETY PRECAUTIONS	1
IMPORTANT NOTE FOR SYSTEM CONNECTION	1
1. DESCRIPTION	3
1.1 Introduction.....	3
1.2 The front panel.....	4
1.3 Front panel properties.....	5
1.4 The rear panel.....	6
2. INSTALLATION	7
2.1 Mechanical assembly.....	7
2.2 Operating conditions.....	7
2.3 Electrical connection.....	8
2.4 PC Connection.....	9
3. MODBUS RTU PROTOCOL	10
3.1 Modbus functions.....	10
3.2 Features of connection cable.....	11
3.3 I/O Relay Status Register.....	11
3.4 Learning of device informations(2BH).....	11
3.5 Reading and writing to data logs from device (14H).....	11
3.6 File record information table.....	11
3.7 Energy log table.....	12
3.8 Error codes.....	12
3.9 MPR-SW (Interface Program).....	12
3.10 Data register map (16 bit).....	13
3.11 Data register map (32 bit).....	14
3.12 Setup register map (16 bit) (MPR60S).....	15
3.13 Setup register map (16 bit) (MPR60S-10).....	16
3.14 Setup register map (16 bit) (MPR60S-20).....	17
3.15 Setup register map (16 bit) (MPR60S-21).....	18
3.16 Setup register map (16 bit) (MPR60S-40).....	19
3.17 Setup register map (16 bit) (MPR60S-41).....	20
4. GENERAL MENU	21
4.1 Setup.....	21
4.2 Network.....	21
4.3 Setting the date and time.....	22
4.4 PC Communication Settings (RS-485).....	22
4.5 Datalog.....	23
4.6 Output Relays and Digital Outputs (Relay 1 and Relay 2).....	24
4.7 Pulse Outputs (Pulse A and Pulse R) (MPR60S/MPR60S-21/41).....	27
4.8 Digital Inputs (3. Input-1 / 4. Input-2) (MPR60S-10/20/40).....	29
4.9 Display.....	30
4.10 Instantaneous Values.....	30
4.11 Energy.....	33
4.12 Demand.....	35
4.13 Observing the time and date.....	38
4.14 Info.....	40
4.15 Manufacturer-Product Information.....	41
4.16 Password.....	42
4.17 Parameter Table.....	43
4.18 Formulas.....	43
4.19 Current Analog Output (0/4-20mA) (MPR60S-40/41).....	44
4.20 Voltage Analog Output (0/2-10V) (MPR60S-20/21).....	45
4.21 Factory Settings.....	46
4.22 Technical Data.....	47
5. STANDART AND EXPLANATIONS	48

1. DESCRIPTION

1.1 INTRODUCTION

Device is a network analyser in 96x96 mm dimension with a non-flammable enclosure. It is designed for measuring all electrical parameters of an electric network with MODBUS-RTU Protocol on RS-485 communication port in order to communicate with the computer.

Device, based on DSP (Digital Signal Processor), is designed for the purpose of measuring all parameters in industry plants and recording these parameters to its memory. The measured parameters can be displayed on LCD screen which has dimension of 3.6 inch and can be read easily in dark environments by activating the Back-Light function. Device contains a MODBUS serial interface option.



Figure 2: General view of the device.

1.2 THE FRONT PANEL

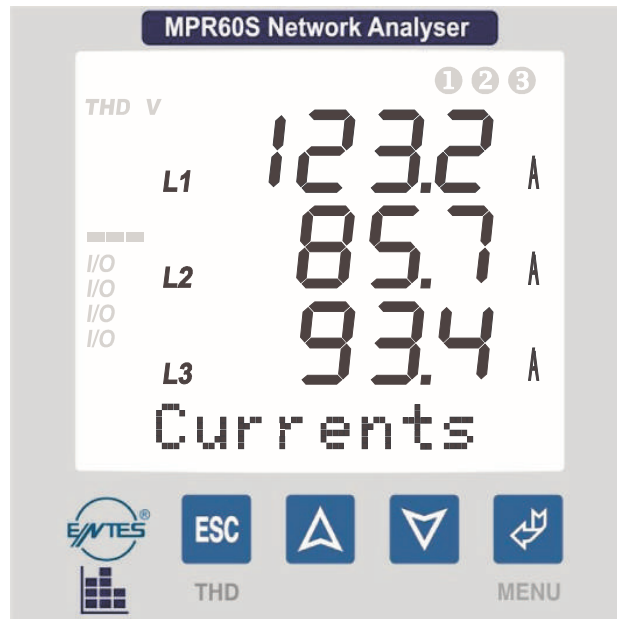





Figure 3: Display and buttons.

Four buttons provide access to programming and measurement screens. The display is LCD and has a white backlight.

KEY FUNCTIONS

BUTTON	FUNCTION
	Exit from a menu any time (THD I and THD V can also be displayed)
	Go to next menu or increase related value
	Go to the previous menu or decrease related value
	Enter to a menu or confirm the data entry

1.3 DISPLAY

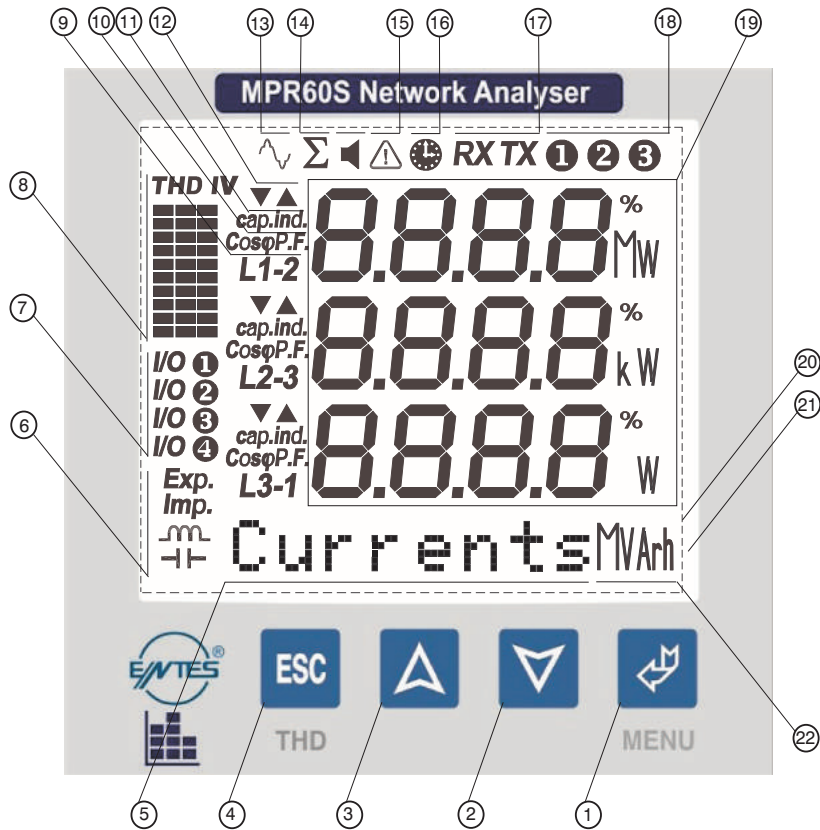

- 1 Menu (ENTER) button.
- 2 Down button.
- 3 Up button.
- 4 ESC button. Exits from a menu or settings at any time.
(THD I, THD V can also be displayed)
- 5 Menu / Energy line : Shows the present menu. / It also shows the energy values.
- 6 Shows whether the value in the Energy Menu is Export, Import, Inductive or capacitive.
- 7 Active output is indicated.
- 8 Harmonic bars: The total harmonics of the 3 phases are displayed in bar graphs.
The columns represent L1, L2 and L3 phases. Each step indicate 10% increase / decrease V is for the voltages harmonics and I is for the currents harmonics.
- 9 Indicates if the measure is phase to phase or phase to neutral.
- 10..... The Cosφ or PF (Power Factor) value of the related phase.
- 11 Indicates if the measurement is capacitive or inductive.
- 12 Min. and Max. symbols for the demand menu.
- 13 Indicates that the harmonics are displayed on the screen.
- 14 Total symbol. Shows the total value of the related measurement.
- 15 Phase sequence failure
- 16 Demand symbol. Shows the demand value of the related parameter.
- 17 PC Communication indicator.
- 18 Phase indication symbols.
- 19 Shows the following measurement values with units.
(V, kV, MV, A, kA, MA, W, kW, MW, VA, kVA, MVA, VAr, kVAr, MVAr %)
- 20 3.6" LCD Display.
- 21 Backlight.
- 22 Shows the unit of energy values. (kWh, kVArh, MWh, MVArh)

1.4 THE REAR PANEL

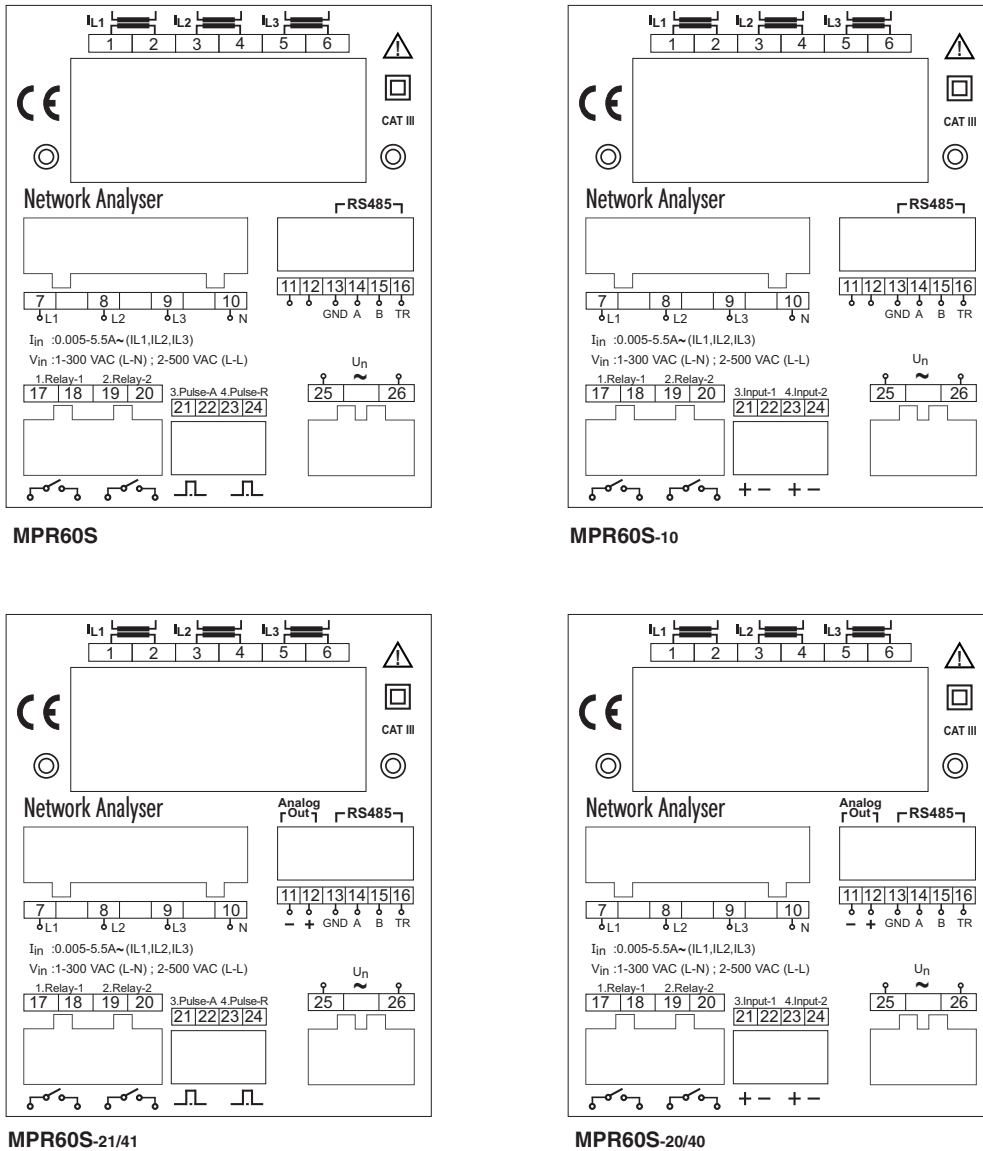
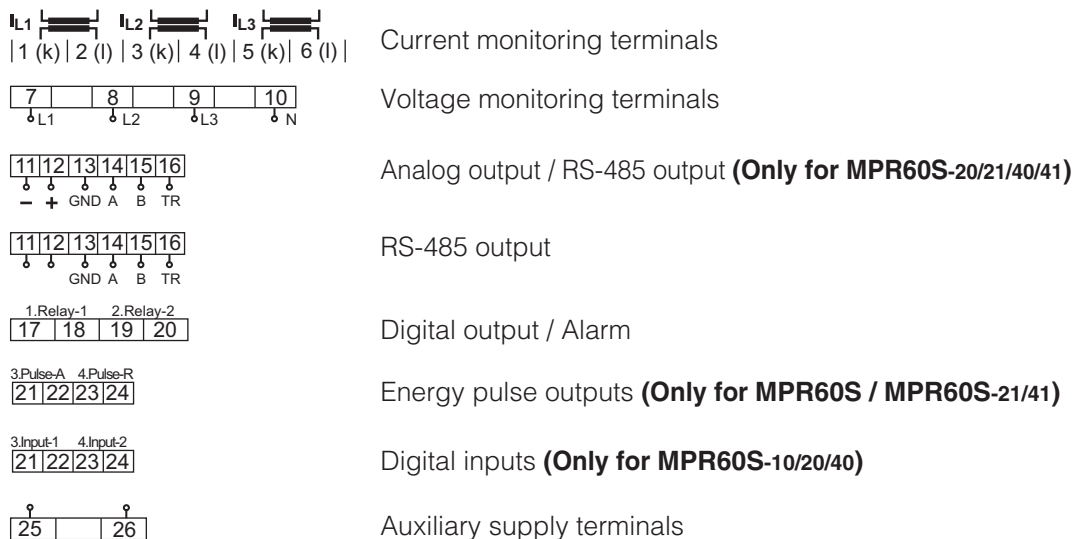

Figure 4: The terminals on the rear panel.



2. INSTALLATION

2.1 MECHANICAL ASSEMBLY

The following drawings are the overall dimensions for the device and the panel cut-out.

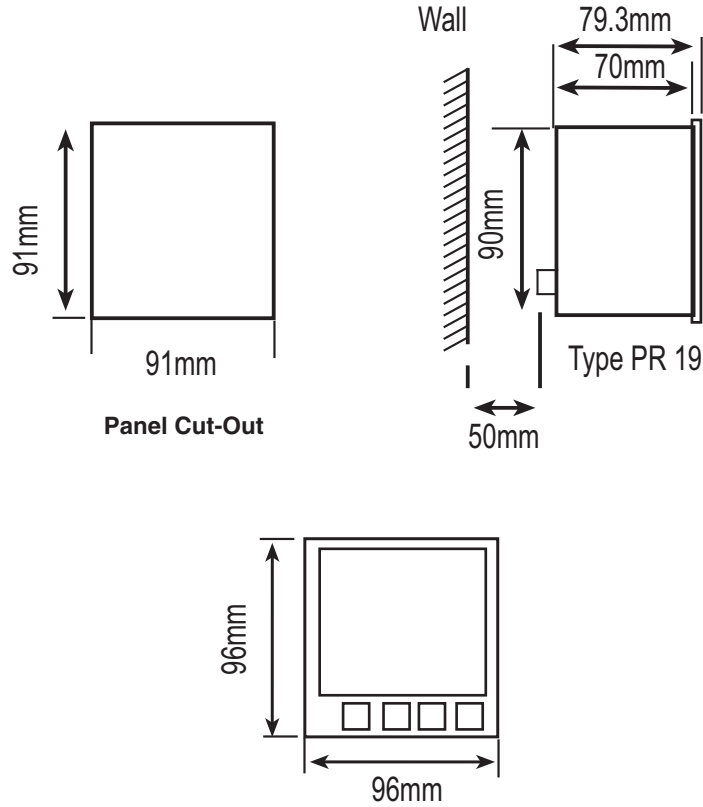

Figure 5: Dimension and the panel cut-out.

2.2 OPERATING CONDITIONS

CLIMATIC ENVIRONMENT

The device should be protected from water / dense moisture and be installed in a covered enclosure when used in a dusty environment. Ambient operating temperature is between -5°C and $+50^{\circ}\text{C}$

ELECTRICAL ENVIRONMENT

Although the device is protected against electrical current fluctuations, it is advisable to avoid the immediate proximity of equipment generating heavy drains (high power contactors, sets of busbars, etc.) The quality of communication obtained from the computer bus depends to a large extent on observing these precautions.

2.3 ELECTRICAL CONNECTION

Wire thickness for voltage terminals must be 2.5 mm² and 4.0 mm² for current terminals. For energy pulse outputs and digital inputs the required wire thickness is 1.5 mm². The fuse must be Type FF with 1A current limit.

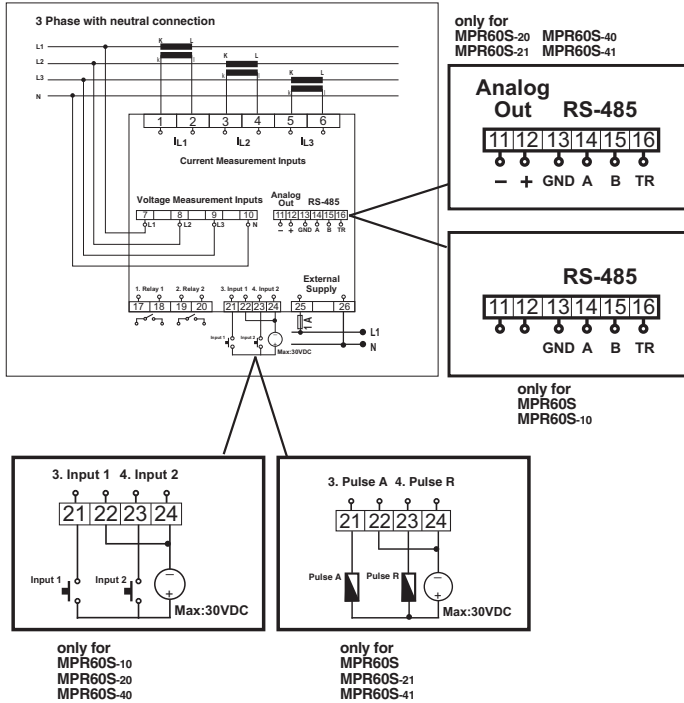

Figure 6: 3 phase with neutral connection

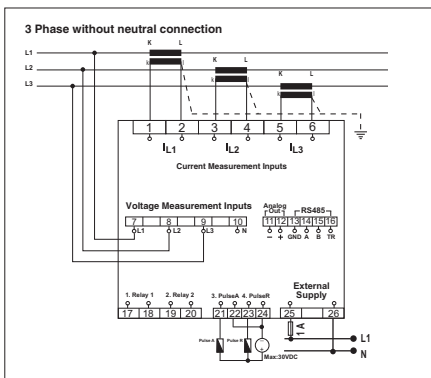

Figure 7: 3 phase without neutral connection

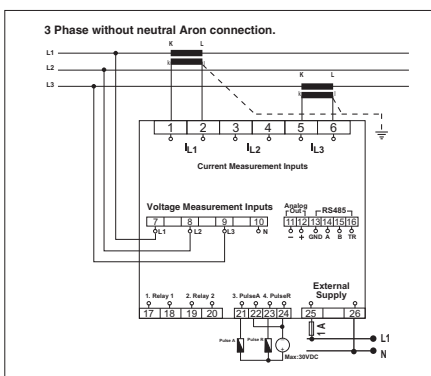

Figure 8: ARON connection (3 phase without neutral connection)

2.4 PC CONNECTION

RS 485/232 Converter is necessary for communicating with computer.

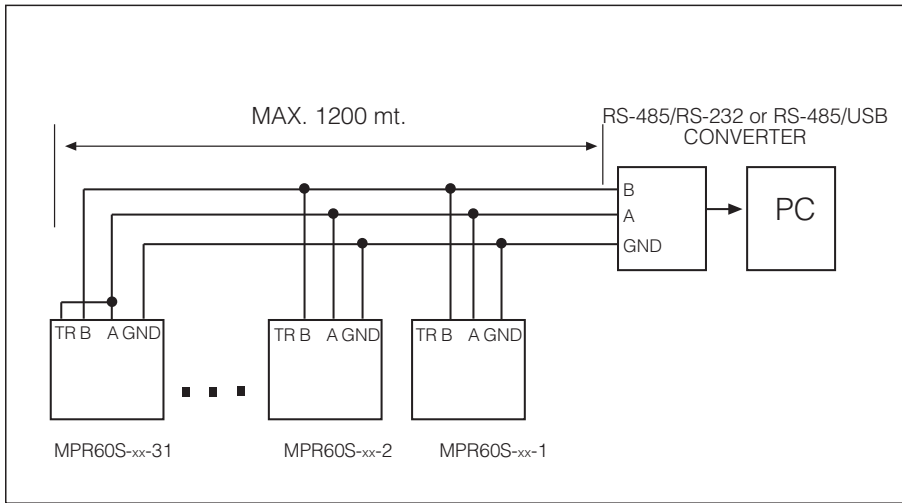

Figure 9: 31 devices can be connected to the same line.

After 20 pieces of device, a repeater is advised for amplifying the data signal.

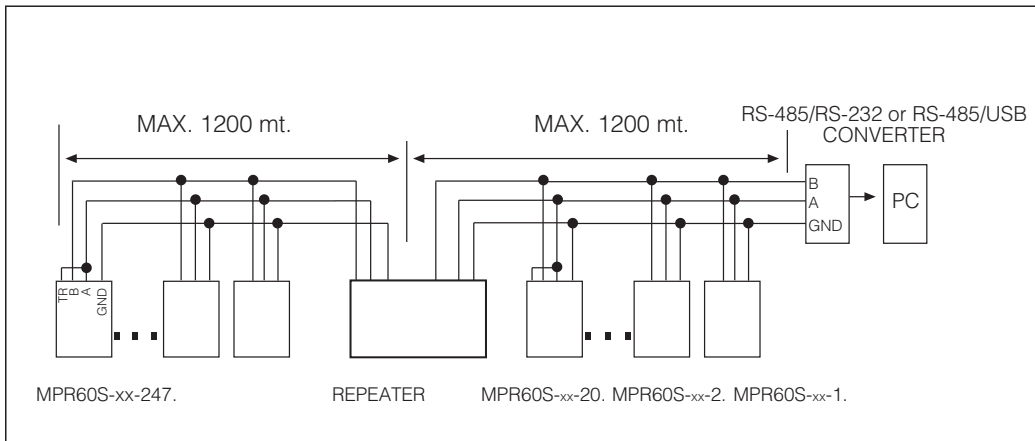

Figure 10: By using repeaters, 247 devices can be connected to the same line.

3. MODBUS RTU PROTOCOL

MODBUS RTU PROTOCOL

Standard message format of MODBUS RTU is as below :

T	ADDRESS 8 BITS	FUNCTION 8 BITS	DATA N x 8 BITS	CRCH	CRCL	T
---	-------------------	--------------------	--------------------	------	------	---

Starting and finishing of T times, which are as much as 3.5 characters time, are time periods of data lines which must be constant for evaluating by devices at the line if the message starts or finishes.

Address area, which is between 1 and 247, shows the serial address of device at the line.

Data area contains the data which is sent to device from slave to master or from master to slave.

CRC is a determination method of error which is used at the MODBUS RTU Protocol and it has 2 bytes

3.1 Modbus Functions:

03H	REGISTER READING	14H	LOG DATA RECORD READING
06H	SINGLE REGISTER WRITING	2BH	DEVICE INFORMATION READING
10H	MULTIPLE REGISTER WRITING		

Register Reading (03H) function is used to read measured parameters and transformer ratios. If a register is tried to read except for values, device sends error message.

Example : This message must be sent to the device for reading the phase-neutral voltage of Phase 1;

01 Device address
03 Function
00 MSB address
00 LSB address
00 Register numbers MSB
01 Register numbers LSB
84 CRC MSB
0A CRC LSB

Single register writing command (06) is used to set the transformer ratios or clear any of min., max. or demand values. Current transformer ratio can be entered between 1 and 5000 and voltage transformer ratio can be entered between 1 and 4000. Only "0" (zero) value can be entered to the demand values.

For setting the CT ratio as 100;

01 Device address
06 Function
01 MSB address
00 LSB address
00 Data MSB
64 Data LSB
89 CRC MSB
DD CRC LSB

Multiple register writing command (10H) is used to change more than one register value. For setting the CT ratio as 100 and voltage transformer ratio as 2;

01 Device address
10 Function
01 MSB address
00 LSB address
00 Register number MSB
02 Register number LSB
04 Byte number
00 Data MSB
64 Data LSB
00 Data MSB
C8 Data LSB
BE CRC MSB
76 CRC LSB

RESPONSE

01 Device address
10 Function
01 Register address (high)
00 Register address (low)
00 Number of registers (high)
02 Number of registers (low)
40 CRC (high)
34 CRC (low)

Parameters are transmitted as 16 bit hexadecimal.

For example:

- 230,6 V voltage value of the device is received as 2306 (0902H) and real value is obtained by multiplying to its multiplier (x0,1) and VT ratio
- 1,907A current value is received as 1907 (0773H) and it is multiplied by 0,001 and CT ratio
- -0,78 P.F. value is received as FCF4H. (16 bit signed integer)
- Energy values are sent as 2 words in 16 bit register table.

Energy value = (High x 10.000) + Low

Example :

Low High
 06237819 kWh = 1E8BH 026FH

3.2 Features of connection cable:

- Screened
- 24 AWG or more thickness
- DC resistance : =<100 ohm/km
- Characteristic impedance : 100 ohm for 100kHz
- Capacitor between two conductors : =< 60 pF/m
- Capacitor between one conductor and earth : =< 120 pF/m

3.3 I/O Relay Status Register.

I/O Relay Status register is used to observe the status of device outputs

15	14	13	12	11	10	9	8	7	6	5	4	3	2	1	0
0	0	0	0	0	0	0	0	0	0	0	0	0	0	Relay2	Relay1

(Only for MPR60S/MPR60S-21/41)

15	14	13	12	11	10	9	8	7	6	5	4	3	2	1	0
0	0	0	0	0	0	0	0	0	0	0	0	Input2	Input1	Relay2	Relay1

(Only for MPR60S-10/20/40)

- When Relay 1 is switched on, 0 (zero) bit of I/O Relay Status Register is read as 1 and when Relay 1 is not switched on it is read as 0.
- When Relay 2 is switched on, 1st bit of I/O Relay Status Register is read as 1 and when Relay 2 is not switched on it is read as 0.
- If Relay Functions (Setup register:011AH/012DH) is set to "1" then Relay 1/2 functions as "Digital Output 1/2".

For switch **ON** Relay 1 **Example** : 01 06 00 4C 00 01 CRC
 For switch **ON** Relay 2 **Example** : 01 06 00 4C 00 02 CRC
 For switch **ON** both relays **Example** : 01 06 00 4C 00 03 CRC
 For switch **OFF** both relays **Example** : 01 06 00 4C 00 00 CRC

3.4 Learning of device informations (2BH)

Following data packet is sent to device to learn the device code, program version, manufacturer name and manufacturer web site :

01 2B 0E 01 00 70 77

3.5 Reading and writing to data logs from device (14H)

Modbus RTU 14H function is used to transmit measured parameters to the computer, when the device is not connected with computer.

01 14 07 06 00 00 00 02 00 01 99 24

01 Device address
14 Function
07 Byte number
06 Reference type
00 File number MSB } 0-15
00 File number LSB }
00 Record number MSB } 0-999
02 Record number LSB }
00 Record length MSB } 1
01 Record length LSB }
99 CRC MSB
24 CRC LSB

Answer
01 Device address
14 Function
46 Data length
20 Record length
06 Reference type
00 Record number MSB
02 Record number LSB
02 Record date Day
10 Record date Month
05 Record date Year
19 Record date Hour
07 Record date Minute
23 Record date Second
08 Data 01 MSB
BC Data 01 LSB
08 Data 02 MSB
95 Data 02 LSB
 : : : :
00 Data 28 MSB
00 Data 28 LSB
71 CRC MSB
B0 CRC LSB



Warning : Data logs must be deleted individually for each file.
For deleting the data logs at the File 0, below request must be sent.
Request : 01 06 04 01 00 00 D9 3A
Response : 01 06 04 01 00 00 D9 3A
 record numbers

* Please refer to page 12 for energy log table.

	Log format	Type	Range
1	Index Hi	Word	0..999
	Index Lo		
2	Day Hi	Word	1..31
	Month Lo		
3	Year Hi	Word	00..99
	Hour Lo		
4	Minute Hi	Word	00..59
	Second Lo		
5	Data 01 Hi	Word	0.65535
	Data 01 Lo		
6	Data 02 Hi	Word	0..65535
	Data 02 Lo		
:	:		
31	Data 28 Hi	Word	0.65535
	Data 28 Lo		
32	CRC	Word	CRC16

3.6 File Record Information Table

It shows the number of records, open file and total number of recordings of the files which have data logs.

ADDRESS	DESCRIPTION	DIMENSION
0400H	File which is recorded now. (0-14)	word
0401H	Record numbers at File 0	word
0402H	Record numbers at File 1	word
:	:	:
0410H	Record numbers at energy file	word
0411H	Total record numbers	word



3.7 Energy Log

Index	Energy Log Format	Dimension	Multiplier	Range	Unit
1	Index	Word	Data	0..999	-
2	Day(Hi)	Word	Data	1..31	d
	Month(Lo)			1..12	m
3	Year(Hi)	Word	Data	00..99	y
	Hour (Lo)			00..23	h
4	Minute(Hi)	Word	Data	00..59	m
	Second (Lo)			00..59	s
5	Import Active Energy(Lo)	Word	Data	-	kWh/MWh
6	Import Active Energy(Hi)	Word	Data x 10000	99999999	
7	Export Active Energy (Lo)	Word	Data	-	kWh/MWh
8	Export Active Energy(Hi)	Word	Data x 10000	99999999	
9	Inductive Reactive Energy(Lo)	Word	Data	-	kVArh/MVArh
10	Inductive Reactive Energy(Hi)	Word	Data x 10000	99999999	
11	Capacitive Reactive Energy(Lo)	Word	Data	-	kVArh/MVArh
12	Capacitive Reactive Energy(Hi)	Word	Data x 10000	99999999	
13	Voltage High LN1	Word	Data x VT x 0.1	0...Vmax	V
14	Voltage High LN2	Word	Data x VT x 0.1	0...Vmax	V
15	Voltage High LN3	Word	Data x VT x 0.1	0...Vmax	V
16	Current High Demand L1	Word	Data x CT x 0.001	0...Imax	A
17	Current High Demand L2	Word	Data x CT x 0.001	0...Imax	A
18	Current High Demand L3	Word	Data x CT x 0.001	0...Imax	A
19	Current Demand L1	Word	Data x CT x 0.001	0...Imax	A
20	Current Demand L2	Word	Data x CT x 0.001	0...Imax	A
21	Current Demand L3	Word	Data x CT x 0.001	0...Imax	A
22	Total Curent High Demand	Word	Data x CT x 0.001	0...Imax	A
23	Energy Counter Unit	Word	Data	0:Kilo/1:Mega	-
24	Total Current Demand	Word	Data x CT x 0.001	0...Imax	A
25	Total Active Power Demand	Signed Word	Data x VT x CT	0..±Ptmax	W
26	Total Reactive Power Demand	Signed Word	Data x VT x CT	0..±Qtmax	VA
27	Total Appearnt Power Demand	Word	Data x VT x CT	0..Stmax	VA
28	Frequency	Word	Data x 0.01	45.00..65.00	Hz
29	Total Power Factor	Signed Word	Data x 0.001	-1.000..1.000	-
30	Current Transformer Ratio	Word	Data	1..2000	-
31	Voltage Transformer Ratio	Word	Data x 0.1	1..4000.0	-
32	Energy Pack CRC	Word	Data	CRC 16	-

3.8 ERROR CODES

If an inappropriate message is sent to device in MODBUS-RTU protocol, device sends an error message.

Error codes are mentioned below :

01 Invalid Function

This message is received when a function is used which is not supported by device.

Example :

Request 01 07 04 01 00 00 CRC

Response **01** Device address

87 80 h + 07h

constant invalid function code

01 Error code

82 CRC (high)

30 CRC (low)

02 Invalid Register

This message is received when an address is wanted to reach which is not found in register table of device.

Example :

Request 01 06 50 00 00 CRC

Response **01** Device address

86 80 h + 06h

constant function code

02 Error code

C3 CRC (high)

A1 CRC (low)

03 Invalid Data :

This message is received when data is not found in required value intervals which is wanted to write.

Example :

Request 01 03 00 00 00 FF CRC

Response **01** Device address

83 80 h + 03h

constant function code

03 Error code

01 CRC (high)

31 CRC (low)

3.9 MPR-SW; Interface Program

MPR-SW is a recording and analysis program which is designed to use with all Entes products which has RS-485 outputs. MPR-SW Program records each parameter of the connected Entes products with programmable time intervals, draws graphics, billing for the energy consumption between adjustable dates, with 2 way communication. Maximum 247 devices can communicate with one software.

Device takes 64 samples in each period. For 50 Hz, it takes 3200 samples in one second and for 60 Hz, it takes 3840 samples in one second.



3.10 Data Register Map (16 bit)

ADDRESS	DESCRIPTION	DIMENSION (16 bit)	MULTIPLIER	RANGE	UNIT
0000H	Voltage LN1	Word	Data x VT x 0.1	0 .. Vmax	V
0001H	Voltage LN2	Word	Data x VT x 0.1	0 .. Vmax	V
0002H	Voltage LN3	Word	Data x VT x 0.1	0 .. Vmax	V
0003H	Current LN1	Word	Data x CT x 0.001	0 .. Imax	A
0004H	Current LN2	Word	Data x CT x 0.001	0 .. Imax	A
0005H	Current LN3	Word	Data x CT x 0.001	0 .. Imax	A
0006H	Total Current	Word	Data x CT x 0.001	0 .. Imax	A
0007H	Active Power L1	Signed Int	Data x VT x CT	0 .. ±Pmax	W
0008H	Active Power L2	Signed Int	Data x VT x CT	0 .. ±Pmax	W
0009H	Active Power L3	Signed Int	Data x VT x CT	0 .. ±Pmax	W
000AH	Reactive Power L1	Signed Int	Data x VT x CT	0 .. ±Qmax	VAr
000BH	Reactive Power L2	Signed Int	Data x VT x CT	0 .. ±Qmax	VAr
000CH	Reactive Power L3	Signed Int	Data x VT x CT	0 .. ±Qmax	VAr
000DH	Apparent Power L1	Word	Data x VT x CT	0 .. Smax	VA
000EH	Apparent Power L2	Word	Data x VT x CT	0 .. Smax	VA
000FH	Apparent Power L3	Word	Data x VT x CT	0 .. Smax	VA
0010H	Power Factor L1	Signed Int	Data x 0.001	-1.000 .. 1.000	-
0011H	Power Factor L2	Signed Int	Data x 0.001	-1.000 .. 1.000	-
0012H	Power Factor L3	Signed Int	Data x 0.001	-1.000 .. 1.000	-
0013H	Cos L1	Signed Int	Data x 0.001	-1.000 .. 1.000	-
0014H	Cos L2	Signed Int	Data x 0.001	-1.000 .. 1.000	-
0015H	Cos L3	Signed Int	Data x 0.001	-1.000 .. 1.000	-
0016H	Voltage L12	Word	Data x VT x 0.1	0 .. Vmax	V
0017H	Voltage L23	Word	Data x VT x 0.1	0 .. Vmax	V
0018H	Voltage L31	Word	Data x VT x 0.1	0 .. Vmax	V
0019H	Voltage LN	Word	Data x VT x 0.1	0 .. Vmax	V
001AH	Voltage LL	Word	Data x VT x 0.1	0 .. Vmax	V
001BH	Frequency	Word	Data x 0.01	45.00 .. 65.00	Hz
001CH	Total Active Power	Signed Int	Data x VT x CT	0 .. ±Pt max	W
001DH	Total Reactive Power	Signed Int	Data x VT x CT	0 .. ±Qt max	VAr
001EH	Total Apparent Power	Word	Data x VT x CT	0 .. St max	VA
001FH	THD V1	Word	Data x 0.1	0 .. 900	%
0020H	THD V2	Word	Data x 0.1	0 .. 900	%
0021H	THD V3	Word	Data x 0.1	0 .. 900	%
0022H	THD V3P	Word	Data x 0.1	0 .. 900	%
0023H	THD I1	Word	Data x 0.1	0 .. 900	%
0024H	THD I2	Word	Data x 0.1	0 .. 900	%
0025H	THD I3	Word	Data x 0.1	0 .. 900	%
0026H	THD I3P	Word	Data x 0.1	0 .. 900	%
0027H	*Voltage High LN1	Word	Data x VT x 0.1	0 .. Vmax	V
0028H	*Voltage High LN2	Word	Data x VT x 0.1	0 .. Vmax	V
0029H	*Voltage High LN3	Word	Data x VT x 0.1	0 .. Vmax	V
002AH	*Voltage Low LN1	Word	Data x VT x 0.1	0 .. Vmax	V
002BH	*Voltage Low LN2	Word	Data x VT x 0.1	0 .. Vmax	V
002CH	*Voltage Low LN3	Word	Data x VT x 0.1	0 .. Vmax	V
002DH	*Demand Current High L1	Word	Data x CT x 0.001	0 .. Imax	A
002EH	*Demand Current High L2	Word	Data x CT x 0.001	0 .. Imax	A
002FH	*Demand Current High L3	Word	Data x CT x 0.001	0 .. Imax	A
0030H	*Demand Current Low L1	Word	Data x CT x 0.001	0 .. Imax	A
0031H	*Demand Current Low L2	Word	Data x CT x 0.001	0 .. Imax	A
0032H	*Demand Current Low L3	Word	Data x CT x 0.001	0 .. Imax	A
0033H	*Demand Current L1	Word	Data x CT x 0.001	0 .. Imax	A
0034H	*Demand Current L2	Word	Data x CT x 0.001	0 .. Imax	A
0035H	*Demand Current L3	Word	Data x CT x 0.001	0 .. Imax	A
0036H	*Demand Total Current High	Word	Data x CT x 0.001	0 .. Imax	A
0037H	*Demand Total Current Low	Word	Data x CT x 0.001	0 .. Imax	A
0038H	*Demand Total Current	Word	Data x CT x 0.001	0 .. Imax	A
0039H	*Demand Total Active Power	Signed Int	Data x VT x CT	0 .. Pt max	W
003AH	*Demand Total Reactive Power	Signed Int	Data x VT x CT	0 .. Qt max	VAr
003BH	*Demand Total Apparent Power	Word	Data x VT x CT	0 .. St max	VA
003CH	*Import Active Energy Lo	Word	(Data +)	-	-
003DH	*Import Active Energy Hi	Word	Data x 10000	99999999	kWh/MWh
003EH	*Export Active Energy Lo	Word	(Data +)	-	-
003FH	*Export Active Energy Hi	Word	Data x 10000	99999999	kWh/MWh
0040H	*Inductive Reactive Energy Lo	Word	(Data +)	-	-
0041H	*Inductive Reactive Energy Hi	Word	Data x 10000	99999999	kVArh/MVArh
0042H	*Capacitive Reactive Energy Lo	Word	(Data +)	-	-
0043H	*Capacitive Reactive Energy Hi	Word	Data x 10000	99999999	kVArh/MVArh
0044H	Hour	Word	Data	0 .. 23	h
0045H	Minute	Word	Data	0 .. 59	m
0046H	Second	Word	Data	0 .. 59	s
0047H	Day	Word	Data	0 .. 31	day
0048H	Month	Word	Data	0 .. 12	month
0049H	Year	Word	Data	00 .. 99	year
004AH	Current Transformer Ratio	Word	Data	1 .. 5000	-
004BH	Voltage Transformer Ratio	Word	Data x 0.1	1.0 .. 4000.0	-
004CH	IO Relay Status (only MPR60S/60S-21/41) IO Relay and Control Status (only MPR60S-10/20/40)	Binary	Data & 0x0003 Data & 0x000F	b0:Relay1,b1:Relay2 b0:Relay1,b1:Relay2 b2:Input1, b3:Input2	-
004DH	Total Power Factor	Signed Int	Data x 0.001	-1.000 .. 1.000	-
004EH	Neutral Current	Word	Data x CT x 0.001	0..IN max.	A
004FH	*Demand Total Active Power High	Signed Int	Data x VT x CT	0 .. +Pt max	W
0050H	*Demand Total Reactive Power High	Signed Int	Data x VT x CT	0 .. +Qt max	VAr
0051H	*Demand Total Apparent Power High	Word	Data x VT x CT	0 .. St max	VA
0052H	*Demand Total Active Power Low	Signed Int	Data x VT x CT	0 .. +Pt max	W
0053H	*Demand Total Reactive Power Low	Signed Int	Data x VT x CT	0 .. +Qt max	VAr
0054H	*Demand Total Apparent Power Low	Word	Data x VT x CT	0 .. St max	VA

Word : 16bit Unsigned (0..65,535)
Signed Int : 16bit Signed (-32,768 .. 32,767)

* Writable registers (Only "0" (zero) value can be written)

3.11 Data Register Map (32 bit)

(Following values are multiplied by Voltage and Current Transformer Ratios)

ADDRESS	DESCRIPTION	DIMENSION (32 bit)	MULTIPLIER	RANGE	UNIT
4000H	Voltage LN1	Long	Data x 0.01	0 .. Vmax x VT	V
4002H	Voltage LN2	Long	Data x 0.01	0 .. Vmax x VT	V
4004H	Voltage LN3	Long	Data x 0.01	0 .. Vmax x VT	V
4006H	Current LN1	Long	Data x 0.001	0 .. Imax x CT	A
4008H	Current LN2	Long	Data x 0.001	0 .. Imax x CT	A
400AH	Current LN3	Long	Data x 0.001	0 .. Imax x CT	A
400CH	Total Current	Long	Data x 0.001	0 .. Imax x CT	A
400EH	Active Power L1	Signed Long	Data x 0.01	0 .. ±Pmax x VT x CT	W
4010H	Active Power L2	Signed Long	Data x 0.01	0 .. ±Pmax x VT x CT	W
4012H	Active Power L3	Signed Long	Data x 0.01	0 .. ±Pmax x VT x CT	W
4014H	Reactive Power L1	Signed Long	Data x 0.01	0 .. ±Qmax x VT x CT	VAR
4016H	Reactive Power L2	Signed Long	Data x 0.01	0 .. ±Qmax x VT x CT	VAR
4018H	Reactive Power L3	Signed Long	Data x 0.01	0 .. ±Qmax x VT x CT	VAR
401AH	Apparent Power L1	Long	Data x 0.01	0 .. Smax x VT x CT	VA
401CH	Apparent Power L2	Long	Data x 0.01	0 .. Smax x VT x CT	VA
401EH	Apparent Power L3	Long	Data x 0.01	0 .. Smax x VT x CT	VA
4020H	Power Factor L1	Signed Long	Data x 0.001	-1.000 .. 1.000	-
4022H	Power Factor L2	Signed Long	Data x 0.001	-1.000 .. 1.000	-
4024H	Power Factor L3	Signed Long	Data x 0.001	-1.000 .. 1.000	-
4026H	Cos L1	Signed Long	Data x 0.001	-1.000 .. 1.000	-
4028H	Cos L2	Signed Long	Data x 0.001	-1.000 .. 1.000	-
402AH	Cos L3	Signed Long	Data x 0.001	-1.000 .. 1.000	-
402CH	Voltage L12	Long	Data x 0.01	0 .. Vmax x VT	V
402EH	Voltage L23	Long	Data x 0.01	0 .. Vmax x VT	V
4030H	Voltage L31	Long	Data x 0.01	0 .. Vmax x VT	V
4032H	Voltage LN	Long	Data x 0.01	0 .. Vmax x VT	V
4034H	Voltage LL	Long	Data x 0.01	0 .. Vmax x VT	V
4036H	Frequency	Long	Data x 0.01	45.00 .. 65.00	Hz
4038H	Total Active Power	Signed Long	Data x 0.01	0 .. ±Pt max x VT x CT	W
403AH	Total Reactive Power	Signed Long	Data x 0.01	0 .. ±Qt max x VT x CT	VAR
403CH	Total Apparent Power	Long	Data x 0.01	0 .. St max x VT x CT	VA
403EH	THD V1	Long	Data x 0.1	0 .. 900	%
4040H	THD V2	Long	Data x 0.1	0 .. 900	%
4042H	THD V3	Long	Data x 0.1	0 .. 900	%
4044H	THD V3P	Long	Data x 0.1	0 .. 900	%
4046H	THD I1	Long	Data x 0.1	0 .. 900	%
4048H	THD I2	Long	Data x 0.1	0 .. 900	%
404AH	THD I3	Long	Data x 0.1	0 .. 900	%
404CH	THD I3P	Long	Data x 0.1	0 .. 900	%
404EH	*Voltage High LN1	Long	Data x 0.01	0 .. Vmax x VT	V
4050H	*Voltage High LN2	Long	Data x 0.01	0 .. Vmax x VT	V
4052H	*Voltage High LN3	Long	Data x 0.01	0 .. Vmax x VT	V
4054H	*Voltage Low LN1	Long	Data x 0.01	0 .. Vmax x VT	V
4056H	*Voltage Low LN2	Long	Data x 0.01	0 .. Vmax x VT	V
4058H	*Voltage Low LN3	Long	Data x 0.01	0 .. Vmax x VT	V
405AH	*Demand Current High L1	Long	Data x 0.001	0 .. Imax x CT	A
405CH	*Demand Current High L2	Long	Data x 0.001	0 .. Imax x CT	A
405EH	*Demand Current High L3	Long	Data x 0.001	0 .. Imax x CT	A
4060H	*Demand Current Low L1	Long	Data x 0.001	0 .. Imax x CT	A
4062H	*Demand Current Low L2	Long	Data x 0.001	0 .. Imax x CT	A
4064H	*Demand Current Low L3	Long	Data x 0.001	0 .. Imax x CT	A
4066H	*Demand Current L1	Long	Data x 0.001	0 .. Imax x CT	A
4068H	*Demand Current L2	Long	Data x 0.001	0 .. Imax x CT	A
406AH	*Demand Current L3	Long	Data x 0.001	0 .. Imax x CT	A
406CH	*Demand Total Current High	Long	Data x 0.001	0 .. Imax x CT	A
406EH	*Demand Total Current Low	Long	Data x 0.001	0 .. Imax x CT	A
4070H	*Demand Total Current	Long	Data x 0.001	0 .. Imax x CT	A
4072H	*Demand Total Active Power	Signed Long	Data x 0.01	0 .. Pt max x VT x CT	W
4074H	*Demand Total Reactive Power	Signed Long	Data x 0.01	0 .. Qt max x VT x CT	VAR
4076H	*Demand Total Apparent Power	Long	Data x 0.01	0 .. St max x VT x CT	VA
4078H	*Import Active Energy	Long	Data	99999999	kWh/MWh
407AH	*Export Active Energy	Long	Data	99999999	kWh/MWh
407CH	*Inductive Reactive Energy	Long	Data	99999999	kVArh/MVArh
407EH	*Capacitive Reactive Energy	Long	Data	99999999	kVArh/MVArh
4080H	Hour	Long	Data	0 .. 23	h
4082H	Minute	Long	Data	0 .. 59	m
4084H	Second	Long	Data	0 .. 59	s
4086H	Day	Long	Data	0 .. 31	day
4088H	Month	Long	Data	0 .. 12	month
408AH	Year	Long	Data	00 .. 99	year
408CH	Current Transformer Ratio	Long	Data	1 .. 5000	-
408EH	Voltage Transformer Ratio	Long	Data x 0.1	1.0 .. 4000.0	-
4090H	IO Relay Status (only MPR60S/60S-21/41)	Binary	Data & 0x0003	b0:Relay1,b1:Relay2	-
	IO Relay and Control Status (only MPR60S-10/20/40)		Data & 0x000F	b0:Relay1,b1:Relay2 b2:Input1, b3:Input2	
4092H	Total Power Factor	Signed Long	Data x 0.001	-1.000 .. 1.000	-
4094H	Neutral Current	Long	Data x 0.001	0 .. IN max.	A
4096H	*Demand Total Active Power High	Signed Long	Data x 0.01	0 .. +Pt max x VT x CT	W
4098H	*Demand Total Reactive Power High	Signed Long	Data x 0.01	0 .. +Qt max x VT x CT	VAR
409AH	*Demand Total Apparent Power High	Long	Data x 0.01	0 .. St max x VT x CT	VA
409CH	*Demand Total Active Power Low	Signed Long	Data x 0.01	0 .. +Pt max x VT x CT	W
409EH	*Demand Total Reactive Power Low	Signed Long	Data x 0.01	0 .. +Qt max x VT x CT	VAR
40A0H	*Demand Total Apparent Power Low	Long	Data x 0.01	0 .. St max x VT x CT	VA

Long : 32bit Unsigned (Hi:Lo) 0..4294967295
Signed Long : 32bit Signed (Hi:Lo) -2,147,483,648 .. 2,147,483,647
* Writable registers (Only "0" (zero) value can be written)

3.12 Setup Register Map (16 bit) (for MPR60S)

ADDRESS	DESCRIPTION	DIMENSION (16bit)	MULTIPLIER	UNIT
0100H	Current Transformer Ratio	Word	Data	
0101H	Voltage Transformer Ratio	Word	Data x 0.1	
0102H	Net Type	Word	0:3P4W 1:3P3W 2:ARON	
0103H	Reserved	Word	Data	
0104H	3.Pulse-A Prm.	Word	Data	kWh
0105H	3.Pulse-A Duration	Word	Data	ms
0106H	4.Pulse-R Prm.	Word	Data	kVArh
0107H	4.Pulse-R Duration	Word	Data	ms
0108H	Relay1 Parameter1	Word	Data	
0109H	Relay1 Hi1	Word	Data	
010AH	Relay1 Lo1	Word	Data	
010BH	Relay1 Delay1	Word	Data	sec.
010CH	Relay1 Hysteresis1	Word	Data	
010DH	Reserved	Word	Data	
010EH	Relay1 Parameter2	Word	Data	
010FH	Relay1 Hi2	Word	Data	
0110H	Relay1 Lo2	Word	Data	
0111H	Relay1 Delay2	Word	Data	sec.
0112H	Relay1 Hysteresis2	Word	Data	
0113H	Reserved	Word	Data	
0114H	Relay1 Parameter3	Word	Data	
0115H	Relay1 Hi3	Word	Data	
0116H	Relay1 Lo3	Word	Data	
0117H	Relay1 Delay3	Word	Data	sec.
0118H	Relay1 Hysteresis3	Word	Data	
0119H	Reserved	Word	Data	
011AH	Relay1 Function	Word	0:Alarm / 1:Digital Output	
011BH	Relay2 Parameter1	Word	Data	
011CH	Relay2 Hi1	Word	Data	
011DH	Relay2 Lo1	Word	Data	
011EH	Relay2 Delay1	Word	Data	sec.
011FH	Relay2 Hysteresis1	Word	Data	
0120H	Reserved	Word	Data	
0121H	Relay2 Parameter2	Word	Data	
0122H	Relay2 Hi2	Word	Data	
0123H	Relay2 Lo2	Word	Data	
0124H	Relay2 Delay2	Word	Data	sec.
0125H	Relay2 Hysteresis2	Word	Data	
0126H	Reserved	Word	Data	
0127H	Relay2 Parameter3	Word	Data	
0128H	Relay2 Hi3	Word	Data	
0129H	Relay2 Lo3	Word	Data	
012AH	Relay2 Delay3	Word	Data	sec.
012BH	Relay2 Hysteresis3	Word	Data	
012CH	Reserved	Word	Data	
012DH	Relay2 Function	Word	0:Alarm / 1:Digital Output	
012EH	Reserved	Word	Data	
012FH	Reserved	Word	Data	
0130H	Reserved	Word	Data	
0131H	Log Period	Word	Data	sec.
0132H	Log Event	Word	0:Off / 1:On	
0133H	Log Energy Period	Word	Data	sec.
0134H	Log Par 1	Word	Data	
0135H	Log Par 2	Word	Data	
:	:	:	Data	
014FH	Log Par 28	Word	Data	
:	Reserved	Word	Data	
0156H	Demand Time	Word	Data	minute
0157H	Hour	Word	Data	h
0158H	Minute	Word	Data	m
0159H	Second	Word	Data	s
015AH	Reserved	Word	Data	
015BH	Day	Word	Data	day
015CH	Month	Word	Data	month
015DH	Year	Word	Data	year
015EH	Reserved	Word	Data	
015FH	Reserved	Word	Data	
0160H	Total Energy / Separately	Word	0:Total/1:Separately	
0161H	Serial Number (1,2)	Word (Hi/Lo)	Char.1 / Char.2	ASC II
0162H	Serial Number (3,4)	Word (Hi/Lo)	Char.3 / Char.4	ASC II
0163H	Serial Number (5,6)	Word (Hi/Lo)	Char.5 / Char.6	ASC II
0164H	Serial Number (7,8)	Word (Hi/Lo)	Char.7 / Char.8	ASC II
0165H	Reserved	Word	Data	
0166H	Reserved	Word	Data	
0167H	Reserved	Word	Data	
0168H	Reserved	Word	Data	
0169H	Reserved	Word	Data	
016AH	Reserved	Word	Data	
016BH	Reserved	Word	Data	
016CH	Energy Counter Unit	Word	0:Kilo / 1:Mega	

3.13 Setup Register Map (16bit) (for MPR60S-10)

ADDRESS	DESCRIPTION	DIMENSION (16bit)	MULTIPLIER	UNIT
0100H	Current Transformer Ratio	Word	Data	
0101H	Voltage Transformer Ratio	Word	Data x 0.1	
0102H	Net Type	Word	0:3P4W 1:3P3W 2:ARON	
0103H	Reserved	Word	Data	
0104H	Reserved	Word	Data	
0105H	Reserved	Word	Data	
0106H	Reserved	Word	Data	
0107H	Reserved	Word	Data	
0108H	Relay1 Parameter1	Word	Data	
0109H	Relay1 Hi1	Word	Data	
010AH	Relay1 Lo1	Word	Data	
010BH	Relay1 Delay1	Word	Data	sec.
010CH	Relay1 Hysteresis1	Word	Data	
010DH	Reserved	Word	Data	
010EH	Relay1 Parameter2	Word	Data	
010FH	Relay1 Hi2	Word	Data	
0110H	Relay1 Lo2	Word	Data	
0111H	Relay1 Delay2	Word	Data	sec.
0112H	Relay1 Hysteresis2	Word	Data	
0113H	Reserved	Word	Data	
0114H	Relay1 Parameter3	Word	Data	
0115H	Relay1 Hi3	Word	Data	
0116H	Relay1 Lo3	Word	Data	
0117H	Relay1 Delay3	Word	Data	sec.
0118H	Relay1 Hysteresis3	Word	Data	
0119H	Reserved	Word	Data	
011AH	Relay1 Function	Word	0:Alarm / 1:Digital Output	
011BH	Relay2 Parameter1	Word	Data	
011CH	Relay2 Hi1	Word	Data	
011DH	Relay2 Lo1	Word	Data	
011EH	Relay2 Delay1	Word	Data	sec.
011FH	Relay2 Hysteresis1	Word	Data	
0120H	Reserved	Word	Data	
0121H	Relay2 Parameter2	Word	Data	
0122H	Relay2 Hi2	Word	Data	
0123H	Relay2 Lo2	Word	Data	
0124H	Relay2 Delay2	Word	Data	sec.
0125H	Relay2 Hysteresis2	Word	Data	
0126H	Reserved	Word	Data	
0127H	Relay2 Parameter3	Word	Data	
0128H	Relay2 Hi3	Word	Data	
0129H	Relay2 Lo3	Word	Data	
012AH	Relay2 Delay3	Word	Data	sec.
012BH	Relay2 Hysteresis3	Word	Data	
012CH	Reserved	Word	Data	
012DH	Relay2 Function	Word	0:Alarm / 1:Digital Output	
012EH	Reserved	Word	Data	
012FH	Reserved	Word	Data	
0130H	Reserved	Word	Data	
0131H	Log Period	Word	Data	sec.
0132H	Log Event	Word	0:Off / 1:On	
0133H	Log Energy Period	Word	Data	sec.
0134H	Log Par 1	Word	Data	
0135H	Log Par 2	Word	Data	
:	:	:	Data	
014FH	Log Par 28	Word	Data	
:	Reserved	Word	Data	
0156H	Demand Time	Word	Data	minute
0157H	Hour	Word	Data	h
0158H	Minute	Word	Data	m
0159H	Second	Word	Data	s
015AH	Reserved	Word	Data	
015BH	Day	Word	Data	day
015CH	Month	Word	Data	month
015DH	Year	Word	Data	year
015EH	Reserved	Word	Data	
015FH	Reserved	Word	Data	
0160H	Total Energy / Separately	Word	0:Total/1:Separately	
0161H	Serial Number (1,2)	Word (Hi/Lo)	Char.1 / Char.2	ASC II
0162H	Serial Number (3,4)	Word (Hi/Lo)	Char.3 / Char.4	ASC II
0163H	Serial Number (5,6)	Word (Hi/Lo)	Char.5 / Char.6	ASC II
0164H	Serial Number (7,8)	Word (Hi/Lo)	Char.7 / Char.8	ASC II
0165H	Input 1 Function	Word	0:Real Time / 1:Lacth	
0166H	Input 2 Function	Word	0:Real Time / 1:Lacth	
0167H	Reserved	Word	Word	
0168H	Reserved	Word	Word	
0169H	Reserved	Word	Data	
016AH	Reserved	Word	Data	
016BH	Reserved	Word	Data	
016CH	Energy Counter Unit	Word	0:Kilo / 1:Mega	

3.14 Setup Register Map (16 bit) (for MPR60S-20)

ADDRESS	DESCRIPTION	DIMENSION (16bit)	MULTIPLIER	UNIT
0100H	Current Transformer Ratio	Word	Data	
0101H	Voltage Transformer Ratio	Word	Data x 0.1	
0102H	Net Type	Word	0:3P4W 1:3P3W 2:ARON	
0103H	Reserved	Word	Data	
0104H	Reserved	Word	Data	
0105H	Reserved	Word	Data	
0106H	Reserved	Word	Data	
0107H	Reserved	Word	Data	
0108H	Relay1 Parameter1	Word	Data	
0109H	Relay1 Hi1	Word	Data	
010AH	Relay1 Lo1	Word	Data	
010BH	Relay1 Delay1	Word	Data	sec.
010CH	Relay1 Hysteresis1	Word	Data	
010DH	Reserved	Word	Data	
010EH	Relay1 Parameter2	Word	Data	
010FH	Relay1 Hi2	Word	Data	
0110H	Relay1 Lo2	Word	Data	
0111H	Relay1 Delay2	Word	Data	sec.
0112H	Relay1 Hysteresis2	Word	Data	
0113H	Reserved	Word	Data	
0114H	Relay1 Parameter3	Word	Data	
0115H	Relay1 Hi3	Word	Data	
0116H	Relay1 Lo3	Word	Data	
0117H	Relay1 Delay3	Word	Data	sec.
0118H	Relay1 Hysteresis3	Word	Data	
0119H	Reserved	Word	Data	
011AH	Relay1 Function	Word	0:Alarm / 1:Digital Output	
011BH	Relay2 Parameter1	Word	Data	
011CH	Relay2 Hi1	Word	Data	
011DH	Relay2 Lo1	Word	Data	
011EH	Relay2 Delay1	Word	Data	sec.
011FH	Relay2 Hysteresis1	Word	Data	
0120H	Reserved	Word	Data	
0121H	Relay2 Parameter2	Word	Data	
0122H	Relay2 Hi2	Word	Data	
0123H	Relay2 Lo2	Word	Data	
0124H	Relay2 Delay2	Word	Data	sec.
0125H	Relay2 Hysteresis2	Word	Data	
0126H	Reserved	Word	Data	
0127H	Relay2 Parameter3	Word	Data	
0128H	Relay2 Hi3	Word	Data	
0129H	Relay2 Lo3	Word	Data	
012AH	Relay2 Delay3	Word	Data	sec.
012BH	Relay2 Hysteresis3	Word	Data	
012CH	Reserved	Word	Data	
012DH	Relay2 Function	Word	0:Alarm / 1:Digital Output	
012EH	Analog Output Parameters	Word	Data	
012FH	Analog Output Low	Word	Data	
0130H	Analog Output High	Word	Data	
0131H	Log Period	Word	Data	sec.
0132H	Log Event	Word	0:Off / 1:On	
0133H	Log Energy Period	Word	Data	sec.
0134H	Log Par 1	Word	Data	
0135H	Log Par 2	Word	Data	
:	:	:	Data	
014FH	Log Par 28	Word	Data	
:	Reserved	Word	Data	
0156H	Demand Time	Word	Data	minute
0157H	Hour	Word	Data	h
0158H	Minute	Word	Data	m
0159H	Second	Word	Data	s
015AH	Reserved	Word	Data	
015BH	Day	Word	Data	day
015CH	Month	Word	Data	month
015DH	Year	Word	Data	year
015EH	Reserved	Word	Data	
015FH	Reserved	Word	Data	
0160H	Total Energy / Separately	Word	0:Total/1:Separately	
0161H	Serial Number (1,2)	Word (Hi/Lo)	Char.1 / Char.2	ASC II
0162H	Serial Number (3,4)	Word (Hi/Lo)	Char.3 / Char.4	ASC II
0163H	Serial Number (5,6)	Word (Hi/Lo)	Char.5 / Char.6	ASC II
0164H	Serial Number (7,8)	Word (Hi/Lo)	Char.7 / Char.8	ASC II
0165H	Input 1 Function	Word	0:Real Time / 1:Lacth	
0166H	Input 2 Function	Word	0:Real Time / 1:Lacth	
0167H	Analog Output Type	Word	0: 2-10V / 1: 0-10V	
0168H	Reserved	Word	Data	
0169H	Reserved	Word	Data	
016AH	Reserved	Word	Data	
016BH	Reserved	Word	Data	
016CH	Energy Counter Unit	Word	0:Kilo / 1:Mega	

3.15 Setup Register Map (16 bit) (for MPR60S-21)

ADDRESS	DESCRIPTION	DIMENSION (16bit)	MULTIPLIER	UNIT
0100H	Current Transformer Ratio	Word	Data	
0101H	Voltage Transformer Ratio	Word	Data x 0.1	
0102H	Net Type	Word	0:3P4W 1:3P3W 2:ARON	
0103H	Reserved	Word	Data	
0104H	3.Pulse-A Prm.	Word	Data	kWh
0105H	3.Pulse-A Duration	Word	Data	ms
0106H	4.Pulse-R Prm.	Word	Data	kVArh
0107H	4.Pulse-R Duration	Word	Data	ms
0108H	Relay1 Parameter1	Word	Data	
0109H	Relay1 Hi1	Word	Data	
010AH	Relay1 Lo1	Word	Data	
010BH	Relay1 Delay1	Word	Data	sec.
010CH	Relay1 Hysteresis1	Word	Data	
010DH	Reserved	Word	Data	
010EH	Relay1 Parameter2	Word	Data	
010FH	Relay1 Hi2	Word	Data	
0110H	Relay1 Lo2	Word	Data	
0111H	Relay1 Delay2	Word	Data	sec.
0112H	Relay1 Hysteresis2	Word	Data	
0113H	Reserved	Word	Data	
0114H	Relay1 Parameter3	Word	Data	
0115H	Relay1 Hi3	Word	Data	
0116H	Relay1 Lo3	Word	Data	
0117H	Relay1 Delay3	Word	Data	sec.
0118H	Relay1 Hysteresis3	Word	Data	
0119H	Reserved	Word	Data	
011AH	Relay1 Function	Word	0:Alarm / 1:Digital Output	
011BH	Relay2 Parameter1	Word	Data	
011CH	Relay2 Hi1	Word	Data	
011DH	Relay2 Lo1	Word	Data	
011EH	Relay2 Delay1	Word	Data	sec.
011FH	Relay2 Hysteresis1	Word	Data	
0120H	Reserved	Word	Data	
0121H	Relay2 Parameter2	Word	Data	
0122H	Relay2 Hi2	Word	Data	
0123H	Relay2 Lo2	Word	Data	
0124H	Relay2 Delay2	Word	Data	sec.
0125H	Relay2 Hysteresis2	Word	Data	
0126H	Reserved	Word	Data	
0127H	Relay2 Parameter3	Word	Data	
0128H	Relay2 Hi3	Word	Data	
0129H	Relay2 Lo3	Word	Data	
012AH	Relay2 Delay3	Word	Data	sec.
012BH	Relay2 Hysteresis3	Word	Data	
012CH	Reserved	Word	Data	
012DH	Relay2 Function	Word	0:Alarm / 1:Digital Output	
012EH	Analog Output Parameters	Word	Data	
012FH	Analog Output Low	Word	Data	
0130H	Analog Output High	Word	Data	
0131H	Log Period	Word	Data	sec.
0132H	Log Event	Word	0:Off / 1:On	
0133H	Log Energy Period	Word	Data	sec.
0134H	Log Par 1	Word	Data	
0135H	Log Par 2	Word	Data	
:	:	:	Data	
014FH	Log Par 28	Word	Data	
:	Reserved	Word	Data	
0156H	Demand Time	Word	Data	minute
0157H	Hour	Word	Data	h
0158H	Minute	Word	Data	m
0159H	Second	Word	Data	s
015AH	Reserved	Word	Data	
015BH	Day	Word	Data	day
015CH	Month	Word	Data	month
015DH	Year	Word	Data	year
015EH	Reserved	Word	Data	
015FH	Reserved	Word	Data	
0160H	Total Energy / Separately	Word	0:Total/1:Separately	
0161H	Serial Number (1,2)	Word (Hi/Lo)	Char.1 / Char.2	ASC II
0162H	Serial Number (3,4)	Word (Hi/Lo)	Char.3 / Char.4	ASC II
0163H	Serial Number (5,6)	Word (Hi/Lo)	Char.5 / Char.6	ASC II
0164H	Serial Number (7,8)	Word (Hi/Lo)	Char.7 / Char.8	ASC II
0165H	Reserved	Word	Data	
0166H	Reserved	Word	Data	
0167H	Analog Output Type	Word	0: 2-10V / 1: 0-10V	
0168H	Reserved	Word	Data	
0169H	Reserved	Word	Data	
016AH	Reserved	Word	Data	
016BH	Reserved	Word	Data	
016CH	Energy Counter Unit	Word	0:Kilo / 1:Mega	

3.16 Setup Register Map (16 bit) (for MPR60S-40)

ADDRESS	DESCRIPTION	DIMENSION (16bit)	MULTIPLIER	UNIT
0100H	Current Transformer Ratio	Word	Data	
0101H	Voltage Transformer Ratio	Word	Data x 0.1	
0102H	Net Type	Word	0:3P4W 1:3P3W 2:ARON	
0103H	Reserved	Word	Data	
0104H	Reserved	Word	Data	
0105H	Reserved	Word	Data	
0106H	Reserved	Word	Data	
0107H	Reserved	Word	Data	
0108H	Relay1 Parameter1	Word	Data	
0109H	Relay1 Hi1	Word	Data	
010AH	Relay1 Lo1	Word	Data	
010BH	Relay1 Delay1	Word	Data	sec.
010CH	Relay1 Hysteresis1	Word	Data	
010DH	Reserved	Word	Data	
010EH	Relay1 Parameter2	Word	Data	
010FH	Relay1 Hi2	Word	Data	
0110H	Relay1 Lo2	Word	Data	
0111H	Relay1 Delay2	Word	Data	sec.
0112H	Relay1 Hysteresis2	Word	Data	
0113H	Reserved	Word	Data	
0114H	Relay1 Parameter3	Word	Data	
0115H	Relay1 Hi3	Word	Data	
0116H	Relay1 Lo3	Word	Data	
0117H	Relay1 Delay3	Word	Data	sec.
0118H	Relay1 Hysteresis3	Word	Data	
0119H	Reserved	Word	Data	
011AH	Relay1 Function	Word	0:Alarm / 1:Digital Output	
011BH	Relay2 Parameter1	Word	Data	
011CH	Relay2 Hi1	Word	Data	
011DH	Relay2 Lo1	Word	Data	
011EH	Relay2 Delay1	Word	Data	sec.
011FH	Relay2 Hysteresis1	Word	Data	
0120H	Reserved	Word	Data	
0121H	Relay2 Parameter2	Word	Data	
0122H	Relay2 Hi2	Word	Data	
0123H	Relay2 Lo2	Word	Data	
0124H	Relay2 Delay2	Word	Data	sec.
0125H	Relay2 Hysteresis2	Word	Data	
0126H	Reserved	Word	Data	
0127H	Relay2 Parameter3	Word	Data	
0128H	Relay2 Hi3	Word	Data	
0129H	Relay2 Lo3	Word	Data	
012AH	Relay2 Delay3	Word	Data	sec.
012BH	Relay2 Hysteresis3	Word	Data	
012CH	Reserved	Word	Data	
012DH	Relay2 Function	Word	0:Alarm / 1:Digital Output	
012EH	Analog Output Parameters	Word	Data	
012FH	Analog Output Low	Word	Data	
0130H	Analog Output High	Word	Data	
0131H	Log Period	Word	Data	sec.
0132H	Log Event	Word	0:Off / 1:On	
0133H	Log Energy Period	Word	Data	sec.
0134H	Log Par 1	Word	Data	
0135H	Log Par 2	Word	Data	
:	:	:	Data	
014FH	Log Par 28	Word	Data	
:	Reserved	Word	Data	
0156H	Demand Time	Word	Data	minute
0157H	Hour	Word	Data	h
0158H	Minute	Word	Data	m
0159H	Second	Word	Data	s
015AH	Reserved	Word	Data	
015BH	Day	Word	Data	day
015CH	Month	Word	Data	month
015DH	Year	Word	Data	year
015EH	Reserved	Word	Data	
015FH	Reserved	Word	Data	
0160H	Total Energy / Separately	Word	0:Total/1:Separately	
0161H	Serial Number (1,2)	Word (Hi/Lo)	Char.1 / Char.2	ASC II
0162H	Serial Number (3,4)	Word (Hi/Lo)	Char.3 / Char.4	ASC II
0163H	Serial Number (5,6)	Word (Hi/Lo)	Char.5 / Char.6	ASC II
0164H	Serial Number (7,8)	Word (Hi/Lo)	Char.7 / Char.8	ASC II
0165H	Input 1 Function	Word	0:Real Time / 1:Lacth	
0166H	Input 2 Function	Word	0:Real Time / 1:Lacth	
0167H	Analog Output Type	Word	0: 4-20mA / 1: 0-20mA	
0168H	Reserved	Word	Data	
0169H	Reserved	Word	Data	
016AH	Reserved	Word	Data	
016BH	Reserved	Word	Data	
016CH	Energy Counter Unit	Word	0:Kilo / 1:Mega	

3.17 Setup Register Map (16 bit) (for MPR60S-41)

ADDRESS	DESCRIPTION	DIMENSION (16bit)	MULTIPLIER	UNIT
0100H	Current Transformer Ratio	Word	Data	
0101H	Voltage Transformer Ratio	Word	Data x 0.1	
0102H	Net Type	Word	0:3P4W 1:3P3W 2:ARON	
0103H	Reserved	Word	Data	
0104H	3.Pulse-A Prm.	Word	Data	kWh
0105H	3.Pulse-A Duration	Word	Data	ms
0106H	4.Pulse-R Prm.	Word	Data	kVArh
0107H	4.Pulse-R Duration	Word	Data	ms
0108H	Relay1 Parameter1	Word	Data	
0109H	Relay1 Hi1	Word	Data	
010AH	Relay1 Lo1	Word	Data	
010BH	Relay1 Delay1	Word	Data	sec.
010CH	Relay1 Hysteresis1	Word	Data	
010DH	Reserved	Word	Data	
010EH	Relay1 Parameter2	Word	Data	
010FH	Relay1 Hi2	Word	Data	
0110H	Relay1 Lo2	Word	Data	
0111H	Relay1 Delay2	Word	Data	sec.
0112H	Relay1 Hysteresis2	Word	Data	
0113H	Reserved	Word	Data	
0114H	Relay1 Parameter3	Word	Data	
0115H	Relay1 Hi3	Word	Data	
0116H	Relay1 Lo3	Word	Data	
0117H	Relay1 Delay3	Word	Data	sec.
0118H	Relay1 Hysteresis3	Word	Data	
0119H	Reserved	Word	Data	
011AH	Relay1 Function	Word	0:Alarm / 1:Digital Output	
011BH	Relay2 Parameter1	Word	Data	
011CH	Relay2 Hi1	Word	Data	
011DH	Relay2 Lo1	Word	Data	
011EH	Relay2 Delay1	Word	Data	sec.
011FH	Relay2 Hysteresis1	Word	Data	
0120H	Reserved	Word	Data	
0121H	Relay2 Parameter2	Word	Data	
0122H	Relay2 Hi2	Word	Data	
0123H	Relay2 Lo2	Word	Data	
0124H	Relay2 Delay2	Word	Data	sec.
0125H	Relay2 Hysteresis2	Word	Data	
0126H	Reserved	Word	Data	
0127H	Relay2 Parameter3	Word	Data	
0128H	Relay2 Hi3	Word	Data	
0129H	Relay2 Lo3	Word	Data	
012AH	Relay2 Delay3	Word	Data	sec.
012BH	Relay2 Hysteresis3	Word	Data	
012CH	Reserved	Word	Data	
012DH	Relay2 Function	Word	0:Alarm / 1:Digital Output	
012EH	Analog Output Parameter	Word	Data	
012FH	Analog Output Low	Word	Data	
0130H	Analog Output High	Word	Data	
0131H	Log Period	Word	Data	sec.
0132H	Log Event	Word	0:Off / 1:On	
0133H	Log Energy Period	Word	Data	sec.
0134H	Log Par 1	Word	Data	
0135H	Log Par 2	Word	Data	
:	:	:	Data	
014FH	Log Par 28	Word	Data	
:	Reserved	Word	Data	
0156H	Demand Time	Word	Data	minute
0157H	Hour	Word	Data	h
0158H	Minute	Word	Data	m
0159H	Second	Word	Data	s
015AH	Reserved	Word	Data	
015BH	Day	Word	Data	day
015CH	Month	Word	Data	month
015DH	Year	Word	Data	year
015EH	Reserved	Word	Data	
015FH	Reserved	Word	Data	
0160H	Total Energy / Separately	Word	0:Total/1:Separately	
0161H	Serial Number (1,2)	Word (Hi/Lo)	Char.1 / Char.2	ASC II
0162H	Serial Number (3,4)	Word (Hi/Lo)	Char.3 / Char.4	ASC II
0163H	Serial Number (5,6)	Word (Hi/Lo)	Char.5 / Char.6	ASC II
0164H	Serial Number (7,8)	Word (Hi/Lo)	Char.7 / Char.8	ASC II
0165H	Reserved	Word	Data	
0166H	Reserved	Word	Data	
0167H	Analog Output Type	Word	0: 4-20mA / 1: 0-20mA	
0168H	Reserved	Word	Data	
0169H	Reserved	Word	Data	
016AH	Reserved	Word	Data	
016BH	Reserved	Word	Data	
016CH	Energy Counter Unit	Word	0:Kilo / 1:Mega	



Warning :

You may quit all settings any time by **ESC** key.
You must record any change in the settings by  menu key.

4. GENERAL MENU

4.1 SETUP

In order for correct measurements and applications, make necessary configurations in the SETUP menu. Sub-menus under the SETUP menu and settings are explained in detail below.

4.2 Network

In this menu, current transformer primary value, voltage transformer ratio and system connection type of device are set.

It has 5 sub-menus. “CT:.....”, “VT:.....”, “Net:.....”, “Eng:.....”, “E.Unit:.....”

CT (Current Transformer Ratio)

The current transformer **ratio** is set between 1...5000.

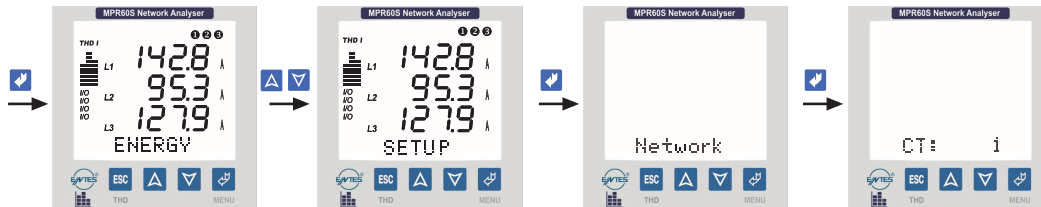

Figure 11: Setting the current transformer ratio

VT (Voltage Transformer Ratio)

The voltage transformer ratio can be adjusted between 1.0...4000.0

Please be careful that this value must be the voltage transformer ratio but not the value of the primary or secondary voltage.

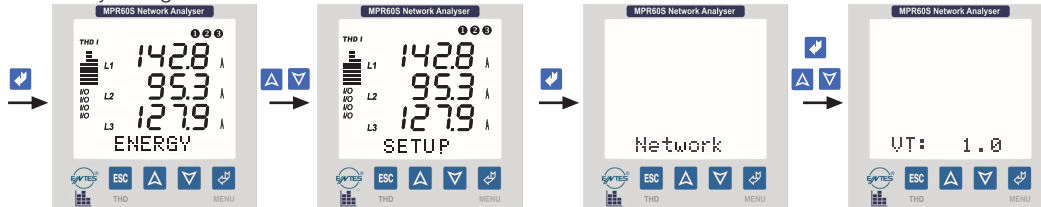

Figure 12: Setting the voltage transformer ratio

Net (Network Type)

The network type is set in this menu.

- 3P4W** : 3 Phase + Neutral (Star connection)
- 3P3W** : 3 Phase without Neutral (Delta connection)
- ARON** : ARON connection.



NOT : In 3P3W connections, as the neutral point is not connected, V_{LN} voltages could be monitored different on unbalanced voltages.

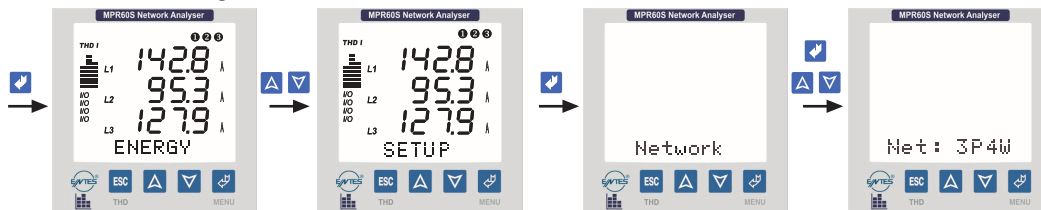

Figure 13: Setting the type of system connection

Eng

If “Tot” menu is selected, device measures the reactive powers of the phases. If the total reactive power of the phases is inductive, it is recorded to the inductive area; If capacitive, it is recorded to the reactive area. If “Sport” menu is selected, device measures the reactive powers of three phases for each phase separately. If it is in the inductive area, it is recorded to the inductive reactive area. If it is in the capacitive area, it is recorded to the capacitive reactive area.

Measurement for each phase separately can be done for 3P4W (3 Phase with Neutral) systems.

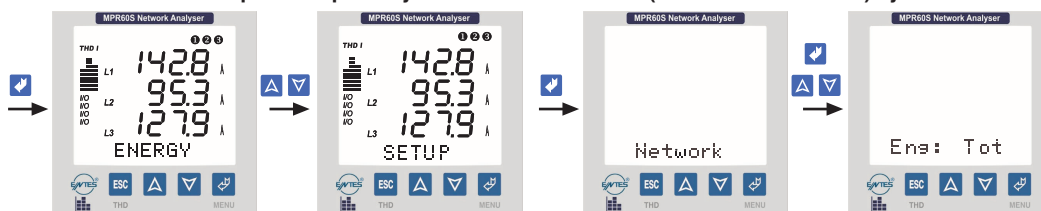

Figure 14: Setting the energy calculation type

E.Unit: (Energy Unit)

It is used for determine the units of energy counters. Counters can be chosen Mega or Kilo.

for example : If energy counter value is 12345678901 kWh when “k” is chosen, 45678901 kWh will be displayed or when “M” is chosen, 12345678 MWh will be displayed.



Warning :

You may quit all settings any time by **ESC** key.
You must record any change in the settings by  menu key.

4.3 Date and Time

It is essential to set the correct date and the time to obtain the right dates on the datalog menu
Date (DD/MM/YYYY)

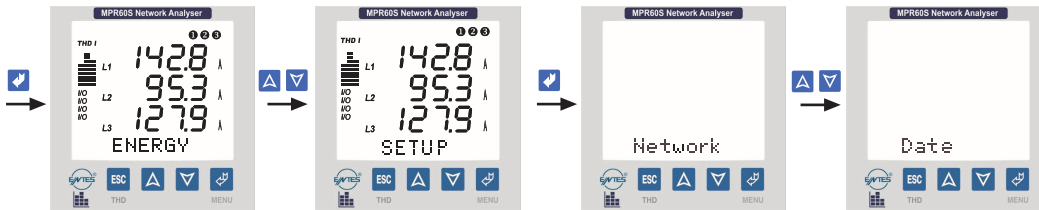

Figure 15: Setting the date

Time (Hour / Minute / Seconds)

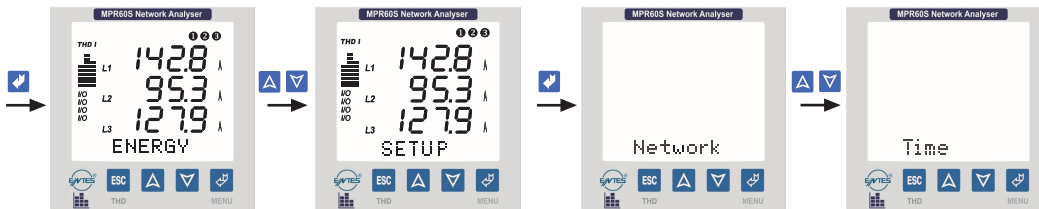

Figure 16: Setting the time

4.4 RS-485 (PC Communication Settings)

All the measured parameters can be transferred to PC through the MPR-SW Software by MODBUS RTU Protocol.
Device can be configured with PC through the MPR-SW Software.

It is necessary to set the Baud Rate, Address and Parity values to the device correctly.

RS-485 has 3 sub-menus “Addr: ...”, “Bd: ...”, “Prt: ...”

Addr (Address Information)

Address Information can be set between 1 and 247.

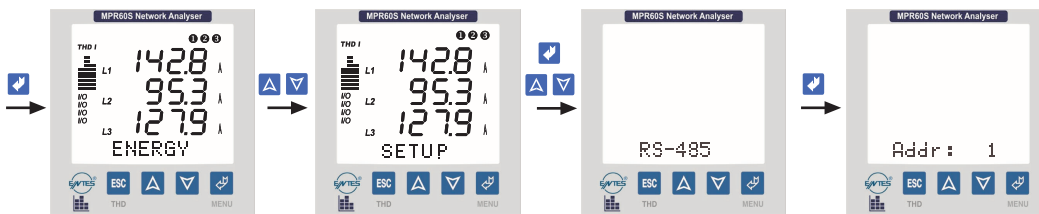

Figure 17: Setting the address information

Bd (Baud Rate Value)

Baud rate is set between 1200 bps and 38400 bps.

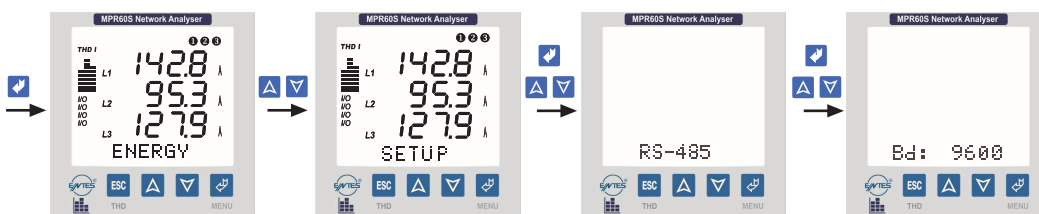



Figure 18: Setting the baud rate value



Warning :

You may quit all settings any time by **ESC** key.
You must record any change in the settings by  menu key.

Prt (Parity Settings)

Parity settings are set as none, even or odd.

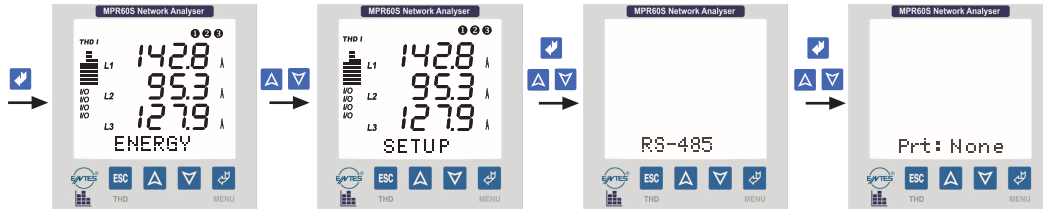

Figure 19: Setting the Parity Settings



IMPORTANT NOTE:

The "PARITY" should be selected as **None** in order to communicate with MPR-SW Software.

4.5 Datalog

Device records the chosen 28 parameters in its 1 MB memory with date and time stamp. The choice of the parameters and recording details are set in Datalog menu. These records can be monitored on the PC and not affected by energy cut off.

The "Datalog" menu has 30 sub-menus.

"Pr1:..." "Pr2:..." "Pr28:..." , "Per:..." , "Event:..."

"Pr1: ..." "Pr2: ..." "Pr28:..." (Parameter Menu)

28 parameters can be associated with these sub menus with one parameter per each menu which will be recorded to memory

15.000 record lines can be stored in memory on the condition, where the total 28 parameters are called as one record line.

At 15.001st record, the first 1000 records are cleared automatically. And then, last record will be read as 14001th.

Note:



Even if less than 28 parameters are entered in sub menus, devices memory allocation is still for 28 parameters for each record line. So assigning less parameters do not increase memory capacity.

Parameter Settings

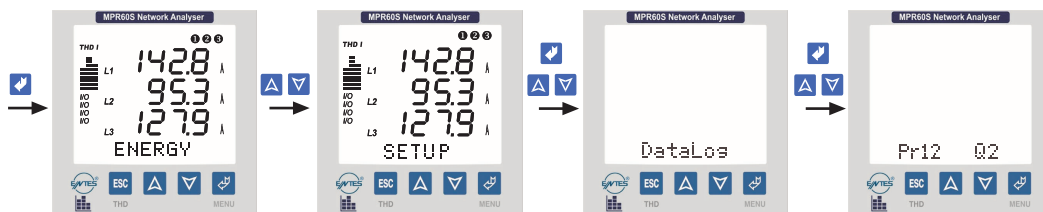

Figure 20: Setting the "Pr12" Parameter

Per (Period Menu)

Period is the time interval between 2 consecutive records and can be set between 5 - 32.000 seconds.

If period is set to "off", then no parameters will be recorded.

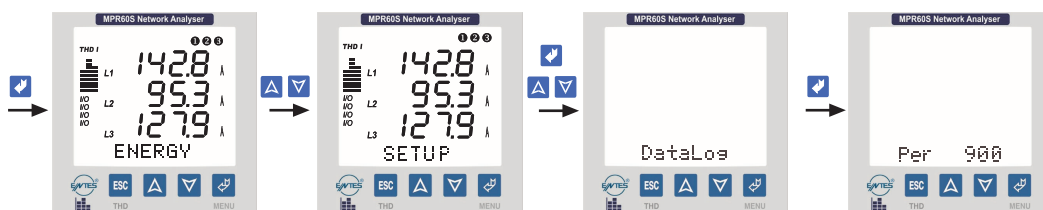



Figure 21: Setting the period time



Warning :

You may quit all settings any time by **ESC** key.
You must record any change in the settings by  menu key.

Event

When “event” is on, the associated parameter array is recorded in case any of the output relays are switched on / off, regardless of period. So, the parameter values can be examined at the time of relay switching on.

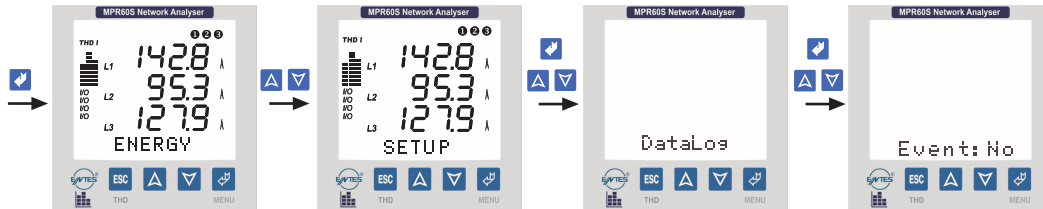

Figure 22: Setting the event

4.6 1. Relay 1 and 2. Relay 2

Device has 2 relays (NO Normally open) for alarm outputs.

Any 3 parameters can be associated with any of the two relays at the same time. For each parameter, under, over, hysteresis and time delay values can be programmed. If the measured value of the set parameter exceeds the programmed values during the delay time, output relay switches on.

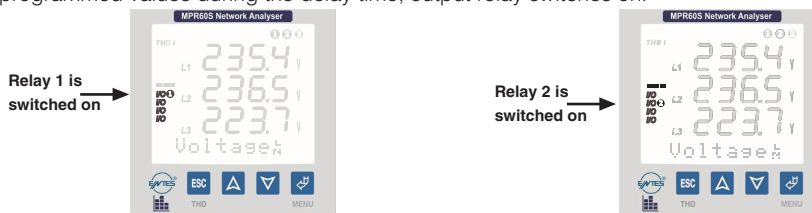

Figure 23: Active relays are displayed on LCD.

1. Relay 1 / (2. Relay 2)

The list of the parameters which can be associated with relays are marked with * on parameter table on page 41.
Relay 1 / (Relay 2) has 16 sub-menus.

- Cfg:** Configuration
- Pr :** Parameter
- Hi :** High (over)
- Lo :** Low (under)
- Hs :** Hysteresis
- Dly :** Time Delay

- Menu of 1st Parameter
“Pr1:...”, “Hi1:...”, “Lo1:...”, “Hs1:...”, “Dly1:...”
- Menu of 2nd Parameter
“Pr2:...”, “Hi2:...”, “Lo2:...”, “Hs2:...”, “Dly2:...”
- Menu of 3rd Parameter
“Pr3:...”, “Hi3:...”, “Lo3:...”, “Hs3:...”, “Dly3:...”

Cfg (Configuration)

By this parameter, relays can be configured as “Alarm Output” (Cfg: Alarm) or as “Remote Control” (Cfg: DOut).

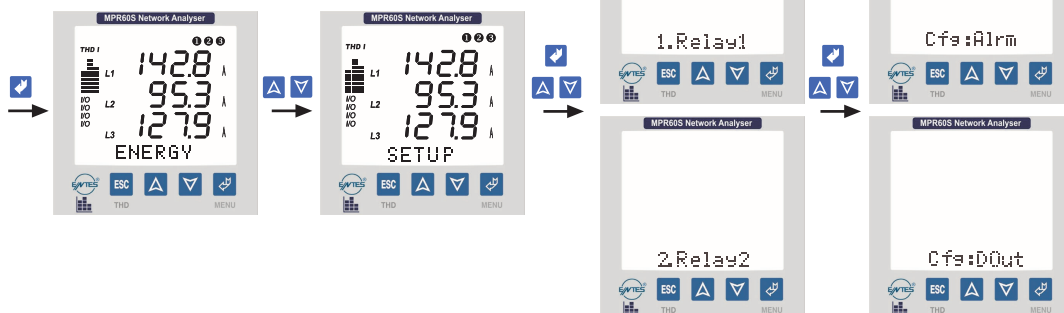
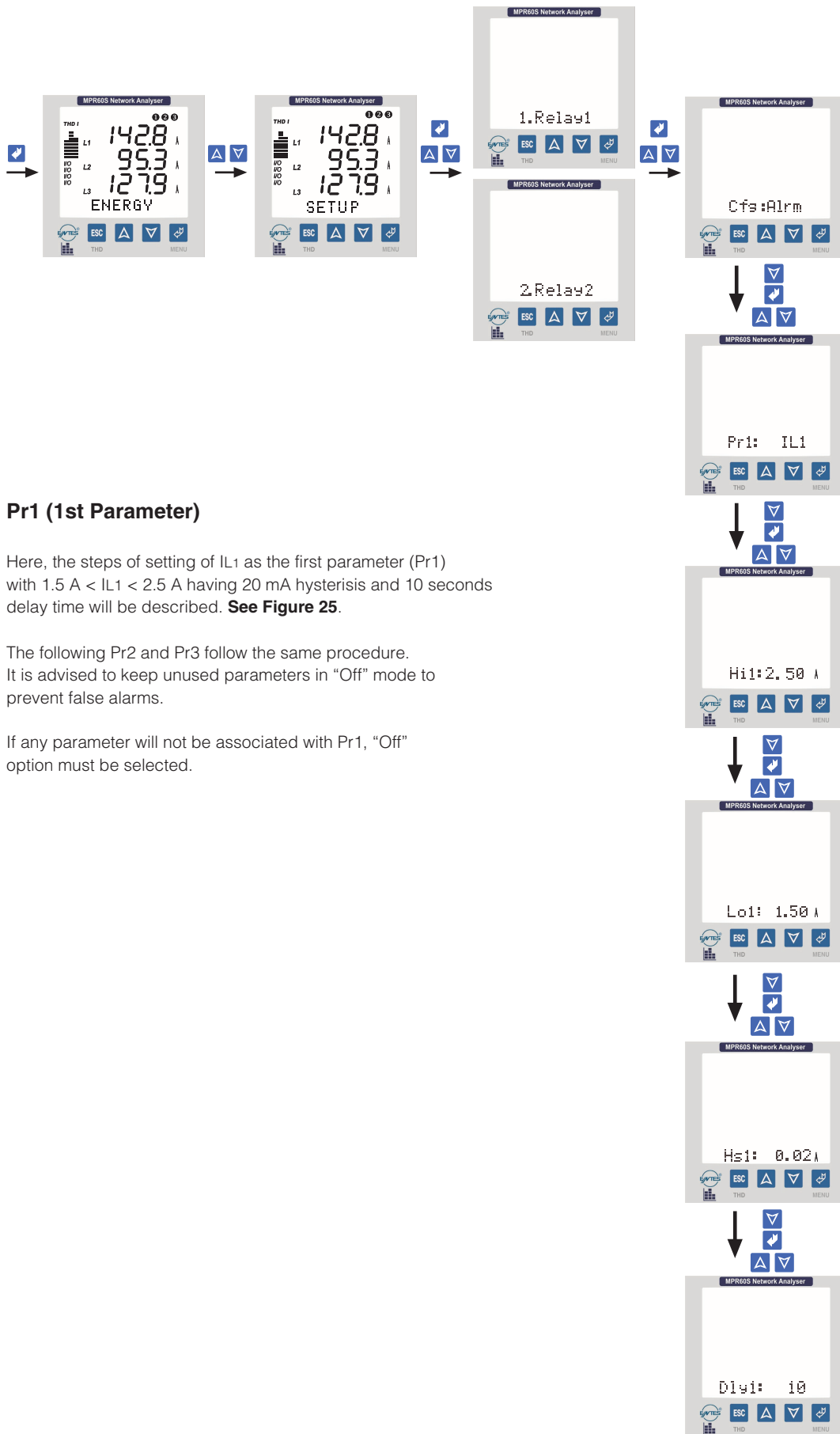

Figure 24: Relay control type setting



Pr1 (1st Parameter)

Here, the steps of setting of IL1 as the first parameter (Pr1) with $1.5\text{ A} < IL1 < 2.5\text{ A}$ having 20 mA hysteresis and 10 seconds delay time will be described. See Figure 25.

The following Pr2 and Pr3 follow the same procedure. It is advised to keep unused parameters in “Off” mode to prevent false alarms.

If any parameter will not be associated with Pr1, “Off” option must be selected.

Figure 25: Setting of IL1 as the first parameter with $1.5\text{ A} < IL1 < 2.5\text{ A}$ having 20 mA hysteresis and 10 seconds delay time.



Warning :

You may quit all settings any time by **ESC** key.
You must record any change in the settings by menu key.

Hi1 (High / over value for the 1st parameter)

When the measured value is over the Hi1 value, Relay 1 (or Relay 2) is switched on complying with Hs1 (Hysterisis 1) and Dly1 (Delay 1) values.

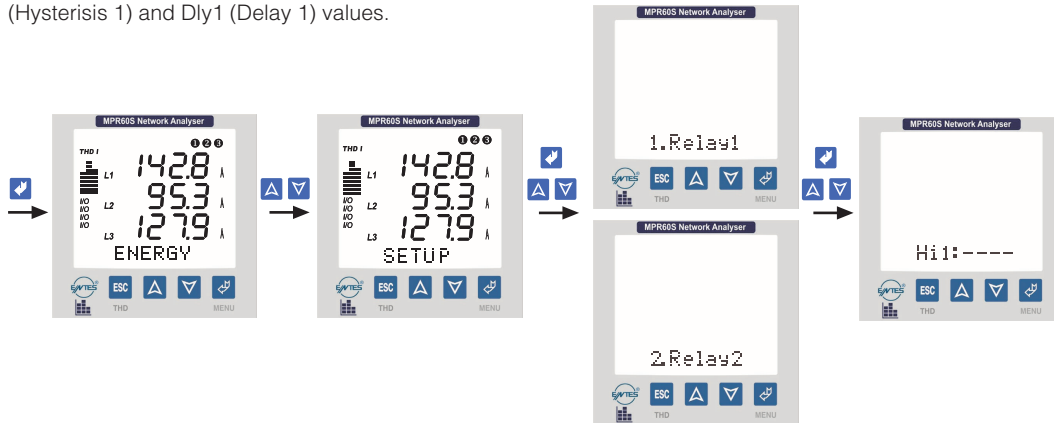

Figure 26: Setting the high (over) value for the 1st parameter

Lo1 (Low / under value for the 1st parameter)

When the measured value is under the Lo1 value, Relay 1 (or Relay 2) is switched on complying with Hs1 (Hysterisis 1) and Dly1 (Delay 1) values.

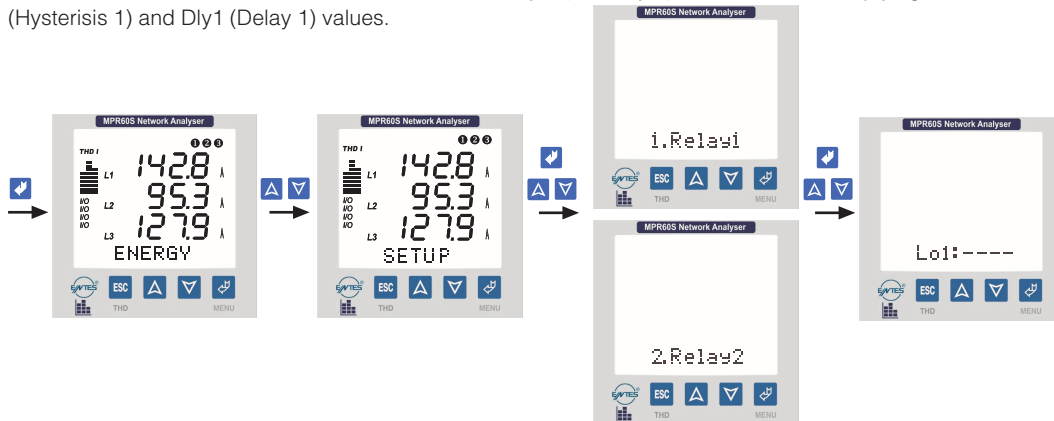

Figure 27: Setting the low (under) value for the 1st parameter

Hs1 (Hysterisis value for the 1st parameter)

This function is added to prevent system from unexpected oscillations during switch off.

When the switch off values of the associated parameters are over (or under) of Lo1 (or Hi1) values as the hysteresis value respectively, the Relay1 switches off.

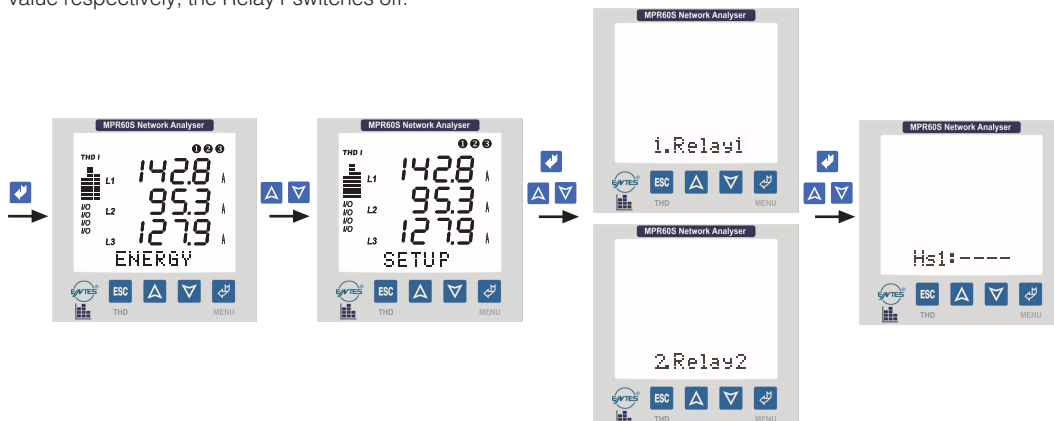



Figure 28: Setting the hysteresis value for the 1st parameter



Warning :

You may quit all settings any time by **ESC** key.
You must record any change in the settings by  menu key.

Dly1 (Delay time for the 1st parameter)

When the triggering signal is sent to the relay1, the relay1 will wait during the delay time before switching on.
If the alarm signal is over during the delay time, the relay1 will not switch on.

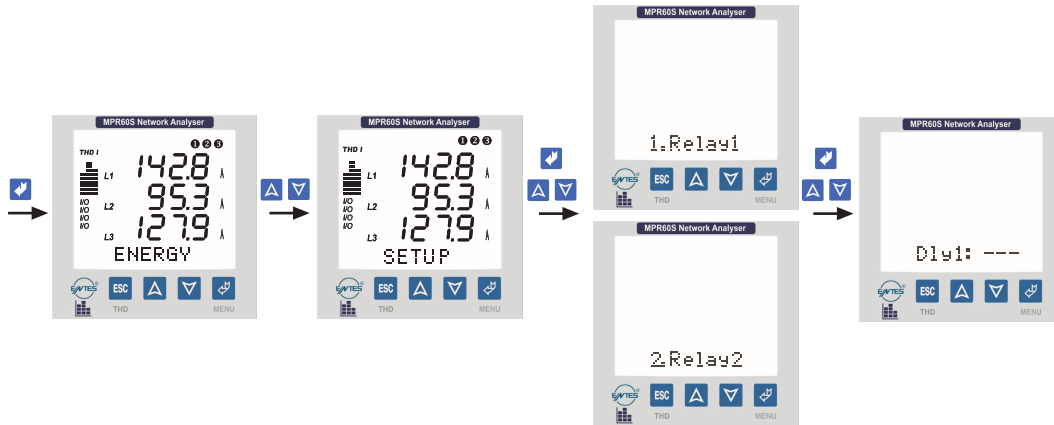
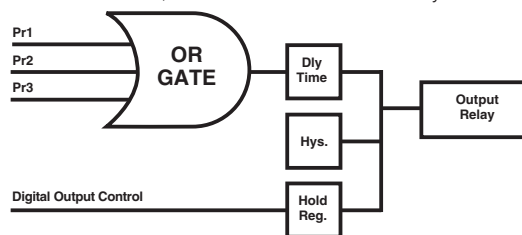

Figure 29: Setting the delay time for the 1st parameter.



Warning

Where more than one parameter is associated with the output relay, and when the output relay is triggered by more than one measure, switch-off will be realized by the last remaining measure.



4.7 Pulse Outputs (3. Pulse A / 4. Pulse R) (MPR60S/MPR60S-21/41)

Device has 2 Pulse Outputs. It is possible to see, which one of these outputs generate pulse, from the LCD at any time.

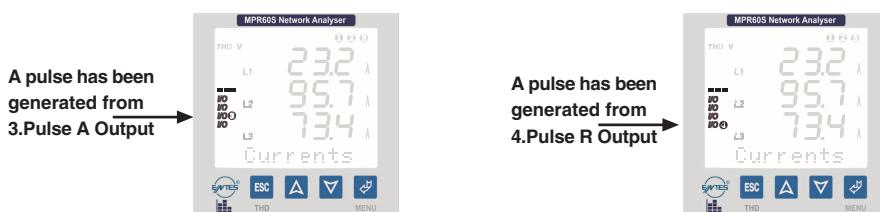

Each time the consumed energy increases by an increment of "Prm", a pulse, as long as the "Dur" value entered (msec), is produced in the Pulse Outputs.

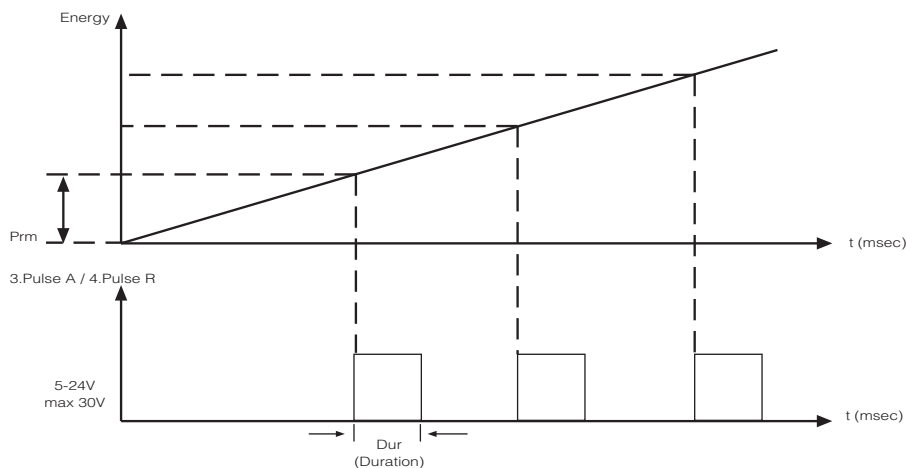



Figure 30: Energy - Pulse output graphic



Warning :

You may quit all settings any time by **ESC** key.
You must record any change in the settings by  menu key.

3. Pulse A (Import Active Energy Pulse Output) /

4. Pulse R (Inductive Reactive Energy Pulse Output)

A pulse is generated in 3. Pulse A relevant with the import active energy value or in 4. Pulse R relevant with the inductive reactive energy value. For example, a pulse for every increase of 10 kWh for 3. Pulse A or for every increase of 10 kVArh for 4. Pulse R.

3. Pulse A (4. Pulse R) has 2 sub-menus. “Prm: ...”, “Dur: ...”

Prm (Import Active / Inductive Reactive Energy Value to Set for 1 Pulse)

A pulse is generated from 3. Pulse A output for each increase of the Prm value by a desired amount (1 kWh...50.0 MWh / 1 kVArh...50.0 MVarh)

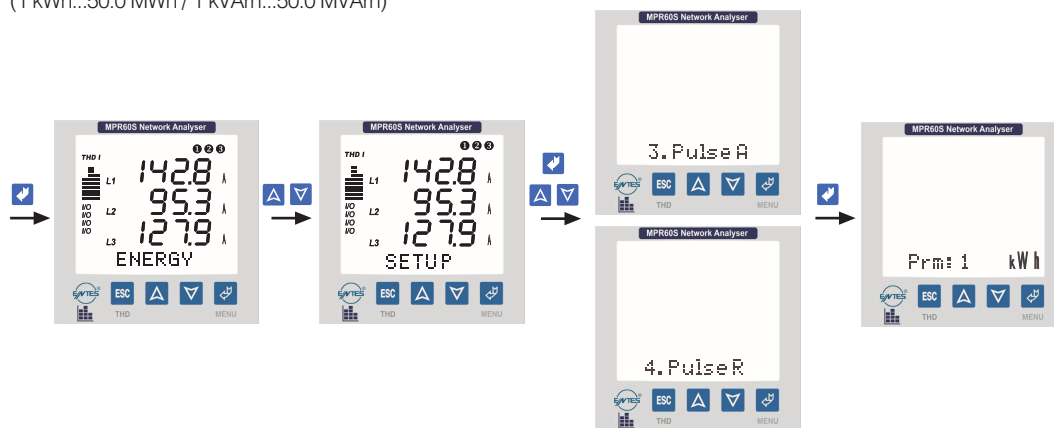

Figure 31: Setting the parameter value

Dur (Pulse Width in Milliseconds)

The pulse width is adjusted between 100 - 2500 msec.

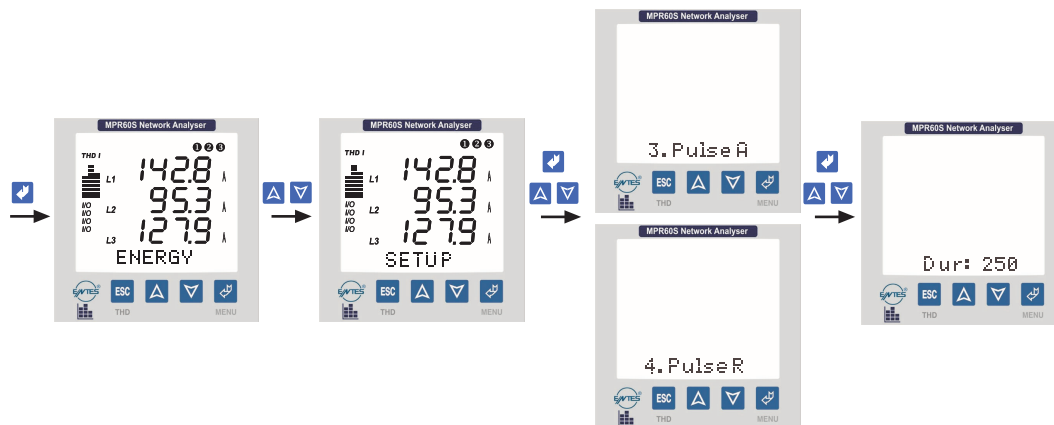

Figure 32: Setting the pulse width.

See page 33 for energy measurement.



Note : Even though the sub-menus under the 3. Pulse A and 4. Pulse R have the same names, these menus are independent of each other.

For Example:

It is possible to enter a specific parameter to the sub-menu “Prm” of 3. Pulse A and a different parameter to the sub-menu “Prm” of 4. Pulse R.



Warning :

You may quit all settings any time by **ESC** key.
You must record any change in the settings by **↓** menu key.

4.8 Digital Inputs (3. Input-1 / 4. Input-2) (Only for MPR60S-10/20/40)

Device has 2 digital inputs. User can monitor the applied voltage to the input on the LCD display.

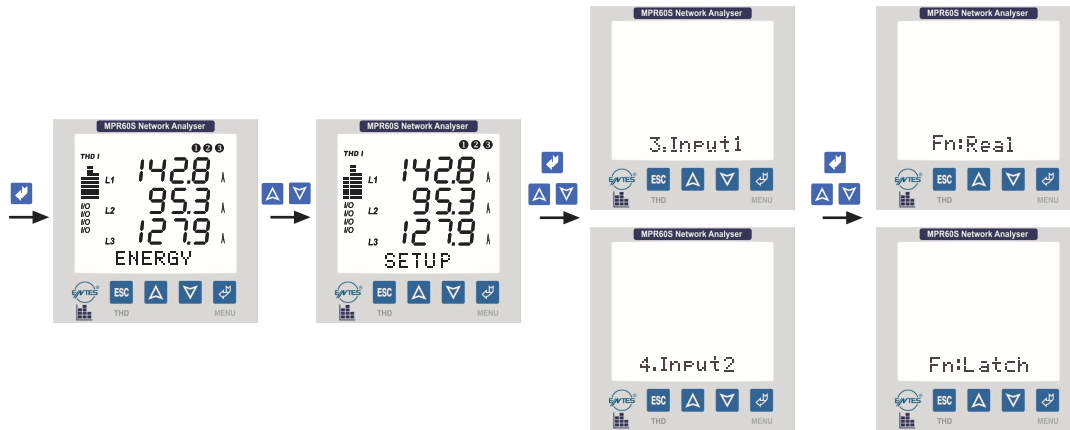

Figure 30: Setting the function value

- In order to configure **Input-1** function, in **0165 H** register:
 - "0" has to be entered for Real Time and
 - "1" has to be entered for Latch.
- In order to configure **Input-2** function, in **0166 H** register:
 - "0" has to be entered for Real Time and
 - "1" has to be entered for Latch.

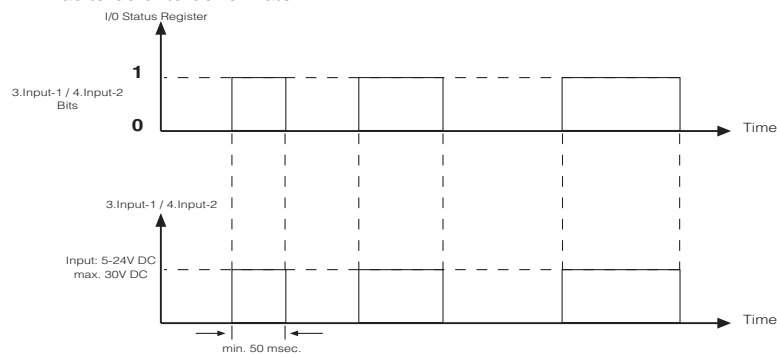

Figure 31: Real Time function operation

- In order to reset input registers, which are set in latch function, "0" bit has to be written in I/O status register.

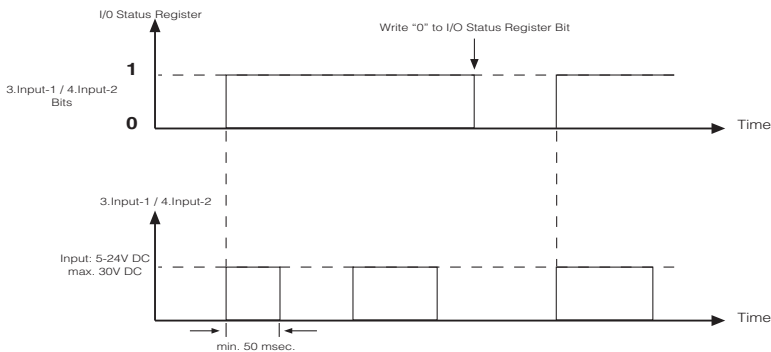

Figure 32: Latch function type operation.

Address: 004C H

15	14	13	12	11	10	9	8	7	6	5	4	3	2	1	0
0	0	0	0	0	0	0	0	0	0	0	0	Input2	Input1	Relay2	Relay1

Input 1 and Input 2 register bits show inputs status.



Warning :

You may quit all settings any time by **ESC** key.
You must record any change in the settings by  menu key.

4.9 Display

In this menu, LCD display settings are configured. It has 3 sub-menus. “Loop: ...”, “Cont: ...”, “BL: ...”

Loop (Loop duration)

In this menu, the duration of displaying instantaneous value is adjusted automatically. The Loop duration can be adjusted as “No” or between 1... 600 in terms of seconds.

For example; when the loop duration is set as 10sec. in the Instantaneous Values menu, if any button is not pressed during 10 sec. the Instantaneous values are displayed in sequence for 10 seconds periods.

By using this function all instantaneous values can be observed sequentially without pressing any buttons.

This function can be cancelled by selecting “No” option in the Loop Menu.

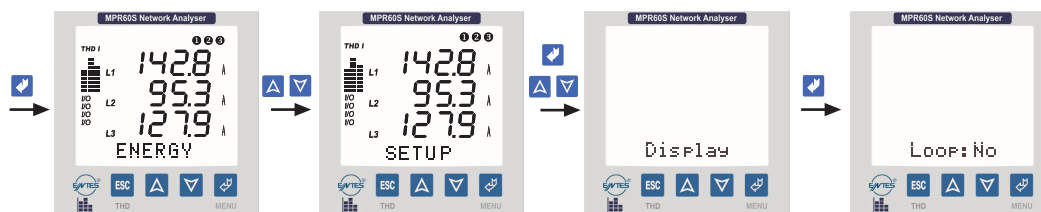

Figure 33: Setting the loop duration

Cont (Contrast - LCD Display Clarity Settings)

The value can be set between 1...6.

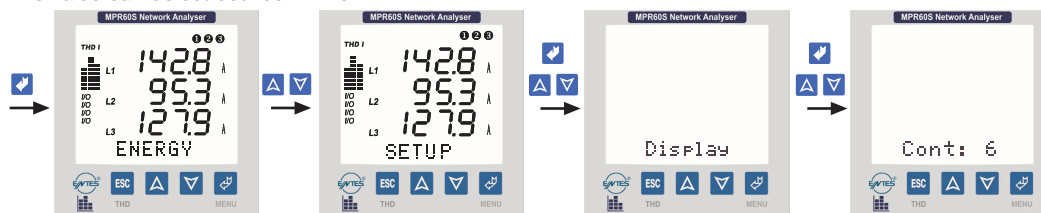

Figure 34: Setting the contrast clarity

BL (Backlight)

Measured values can easily be read on the LCD screen even in dark environments with feature of the backlight function.

On : Backlight is On continuously.

Off : Backlight is Off continuously.

Auto : Backlight is switched on automatically when a button is pressed. It is switched off automatically at the end of 30 seconds if any button is not pressed again.

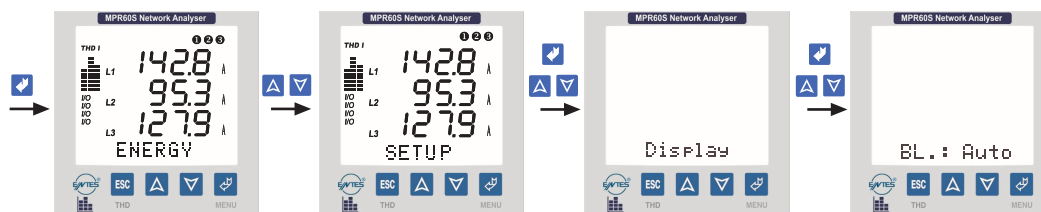

Figure 35: Setting the contrast clarity

4.10 INSTANTANEOUS VALUES

This menu is the last menu that is reached by pressing ESC button while in any menu.

Also it is the main menu of device. If you wait a while without pressing any buttons in any menu, the Instantaneous value menu automatically comes back.

When device is energized for the first time, the device is in the Instantaneous values menu and shows the instantaneous values.

The display is seen as below.

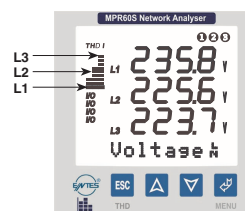

At the bottom of the screen, the active sub-menu is displayed. Each bar on the left indicates the ratio between total harmonic amount of current or voltage for each phase as a percentage value. Each step is 10%. It is possible to switch between "THD V" and "THD I" by ESC button. Also, it is possible to see the numerical values of the THD values by going to the Instantaneous Values Menu.

THD V : Total Harmonic Distortion of Voltage
 THD I : Total Harmonic Distortion of Current

Note: When device's phase voltages exceed 330.0 V, phase-phase voltages exceed 530.0 V, phase currents exceed 5.500 A according to upper limits of measurement, "HIGH" is displayed on display.

By scrolling with **▲** (UP), **▼** (DOWN) buttons while in the Instantaneous Values Menu, the below parameters of the network are displayed.

Voltage _N	-	Voltage _L	-	Currents	-	P. Factor	-	Cosφ	-	Active (W)
Reactive (VAr)	-	Apparent (VA)	-	ΣPowers	-	Σ P.F.	-	THD V %	-	THD I %
Freq. Hz	-	Average _N	-	Average _L	-	ΣCurrent	-	In Neutral Current (A)		

Voltage_N Measured phase-neutral voltage value VL1, VL2, VL3

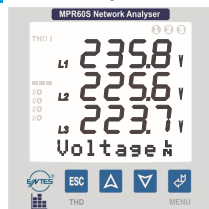

Voltage_L Measured phase-phase voltage value VL1-2, VL2-3, VL3-1

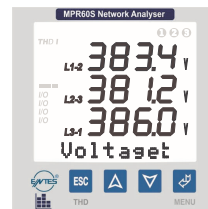

Currents Current measure of each phase IL1, IL2, IL3

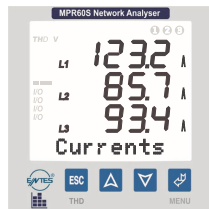

P. Factor Power factor measure of all phases PF L1, PF L2, PF L3

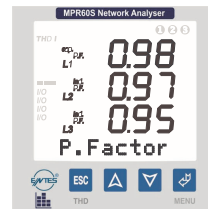

Cosφ Cosφ measure of all phases Cosφ L1, Cosφ L2, Cosφ L3

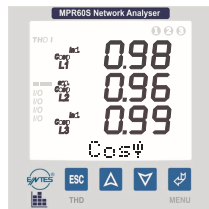

Active Active power measure of all phases P L1, P L2, P L3

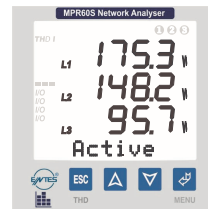

Reactive Reactive power measure of all phases Q L1, Q L2, Q L3

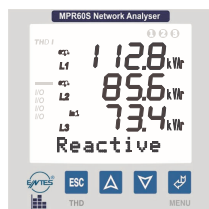

Apparent Apparent power measure of all phases S L1, S L2, S L3

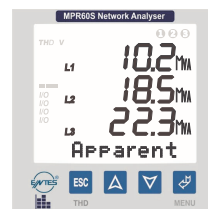

Σ Powers Measured total active, total reactive and total apparent power values
 $\Sigma P, \Sigma Q, \Sigma S$

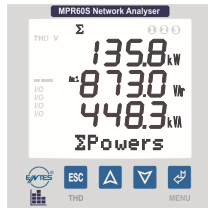

$\Sigma P.F.$ Total power factor values of all phases

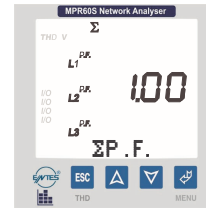

THD V% The total harmonic values for voltages of each phase

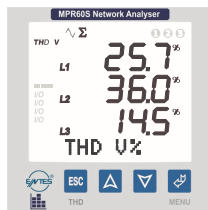

THD I% The total harmonic values for currents of each phase

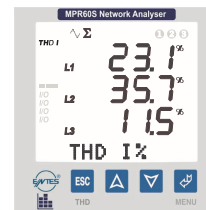

NOTES:

- * If there is "-" symbol before the measured active power, it indicates the existence of active export power.
- * When ARON connection is chose, "L2 - - -" symbol is seen at the **Currents, P.Factor, Cos Φ , Active, Reactive, Apparent, THD I%, DEMAND, max.I.L, DEMAND min.I.L, DEMAND I.L** menus.
- * The total current-voltage harmonic values are displayed in THD V% and THD I% menus as graphic bars on the left. Any time at the instantaneous values menu (except THD V% and THD I%), you can scroll between THD V and THD I with pressing ESC button. Harmonic menu can be used for watching the harmonic values detailed.

Freq. Hz Frequency of the system.
 (The frequency is measured from the L1 phase.)

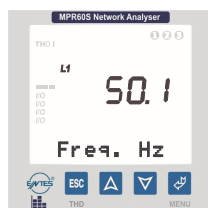

Average V The average value of the measured phase-neutral voltages

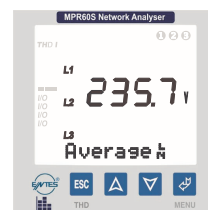

Averaget The average value of the measured phase-phase voltages

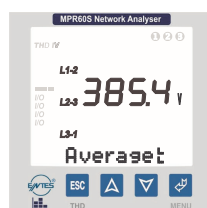

Σ Current The total current value of all phases

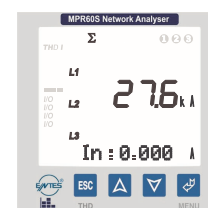
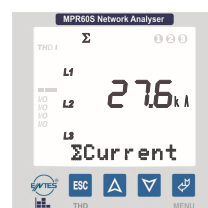

Watching the Values of the Other Parameters

Other parameters are grouped under the; **ENERGY, DEMAND, TIME, DATE** menus.

4.11 ENERGY

The Energy Values:

In this menu, below energy values are displayed and cleared.

Exp. Export Active Energy **Imp.** Import Active Energy

\sim Inductive Reactive Energy \rightarrow Capacitive Reactive Energy values

These energy values can be cleared one by one or all at once.

Imp. (Import Active Energy)

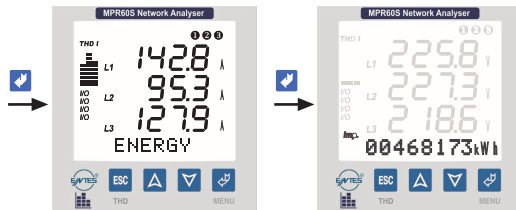

Figure 36: Import Active Energy value

Clearing the Import Active Energy value

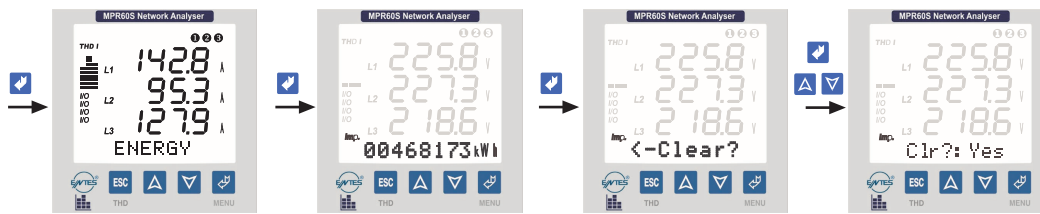

Figure 37: Clearing the Import Active Energy value

Exp. (Export Active Energy value)

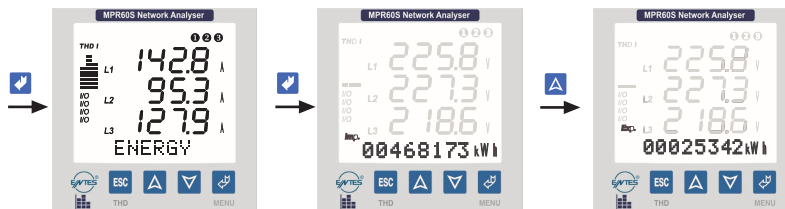

Figure 38: Export Active Energy value

Clearing the Export Active Energy value

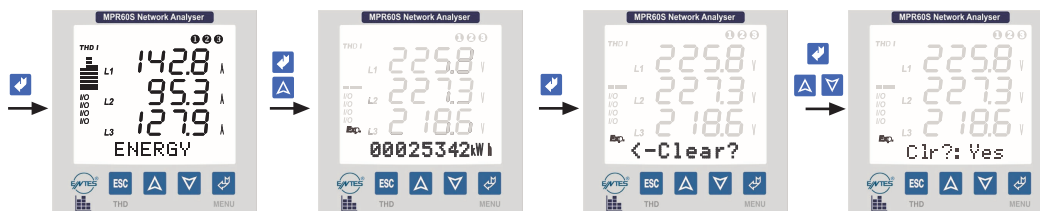

Figure 39: Clearing the Export Active Energy value

Ind. (Inductive Reactive Energy)

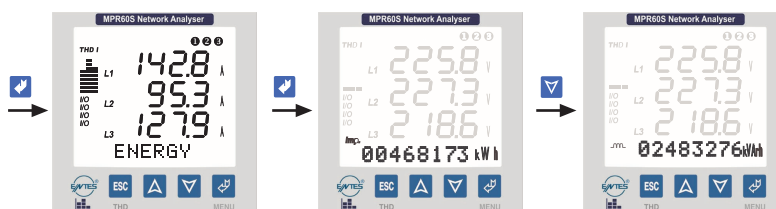



Figure 40: Inductive Reactive Energy value



Warning :

You may quit all settings any time by **ESC** key.

You must record any change in the settings by  menu key.

Clearing the Inductive Reactive Energy value

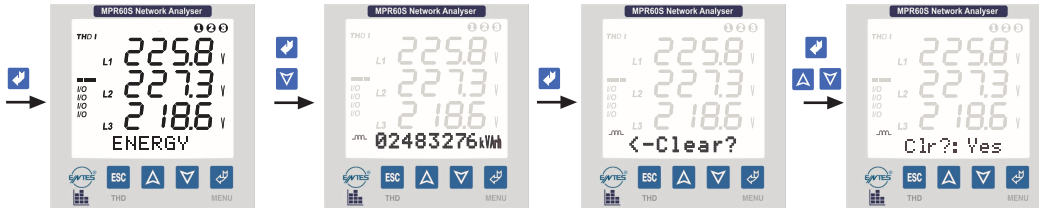

Figure 41: Clearing the Inductive Reactive Energy value

Cap. (Capacitive Reactive Energy)

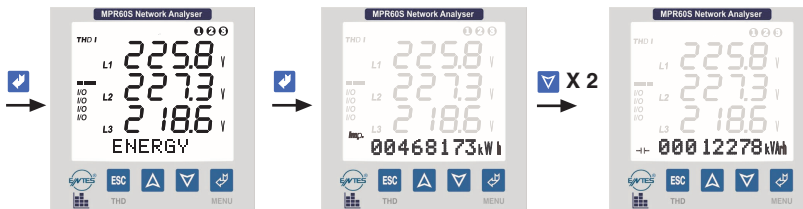

Figure 42: Capacitive Reactive Energy value.

Clearing the Capacitive Reactive Energy value

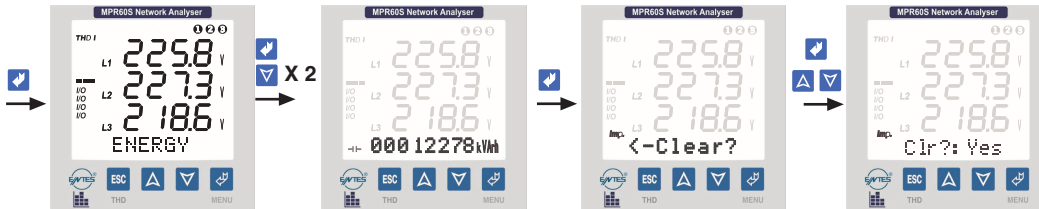

Figure 43: Clearing the Capacitive Reactive Energy value

Clearing all energy values (Exp, Imp, Ind, Cap)

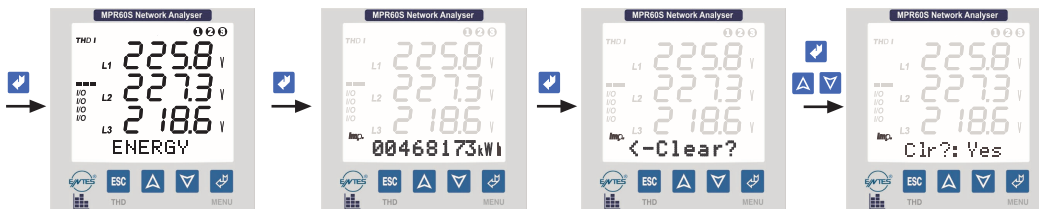



Figure 44: Clearing all energy values

**Warning :**

You may quit all settings any time by **ESC** key.
 You must record any change in the settings by  menu key.

4.13 DEMAND

Observing Demand, min. and max. Values

Demand : It shows the averages which arise on power and current during demand time.

min. value : It shows the min. value different from zero that measured on voltages.

max. value : It shows the max. value that measured on voltages.

***max.VL-N** (max. voltage values between Phase-Neutral)

***min.VL-N** (min. voltage values between Phase-Neutral)

***max. Demand IL** (Max. demand values of phase currents)

***min. Demand IL** (Min. demand values of phase currents)

***Demand IL** (Demand values of phase currents)

***max. Demand ΣI and min. Demand ΣI** (Total max. and min. demand values of phase current)

***Demand ΣIL** (Demand value of total phase current)

***Demand ΣP , Demand ΣQ and Demand ΣS** (Demand values of total power values)

max. Demand ΣP , max. Demand ΣQ and max. Demand ΣS (Max. demand values of total powers)

min. Demand ΣP , min. Demand ΣQ and min. Demand ΣS (Min. demand values of total powers)

Minimum, maximum and demand values can be cleared one by one or all at once.

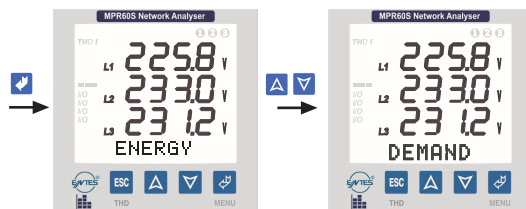

Figure 45: Demand values

max. VLN (Max. values of the phase-neutral voltages)

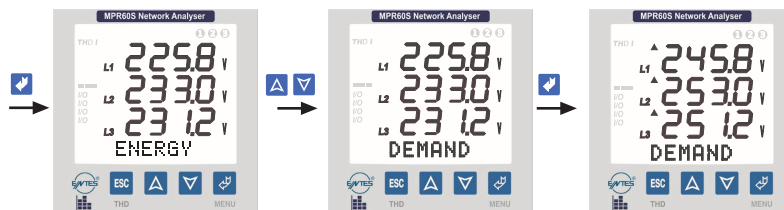

Figure 46: Max. VLN

Clearing the max. VLN (Max. values of the phase-neutral voltages)

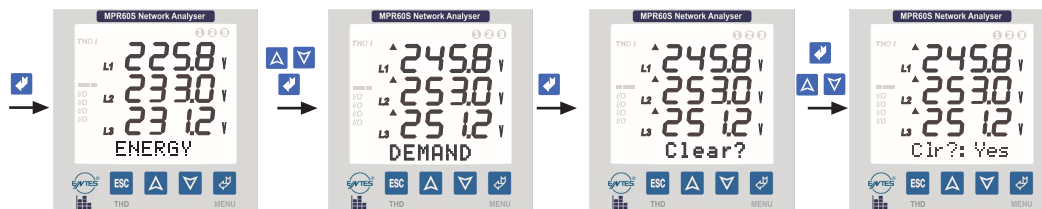

Figure 47: Clearing the max. VLN

Observing the min. VLN (Min. values of the phase-neutral voltages)

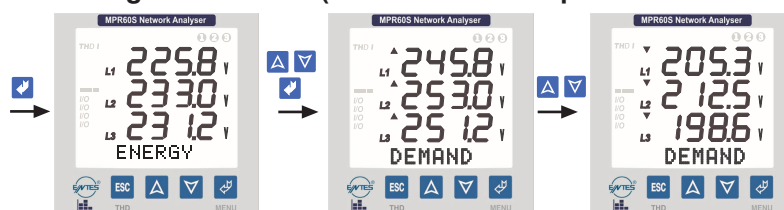



Figure 48: Min. VLN value



Warning :

You may quit all settings any time by **ESC** key.
You must record any change in the settings by  menu key.

Clearing the min. VLN (Min. values of the phase-neutral voltages)

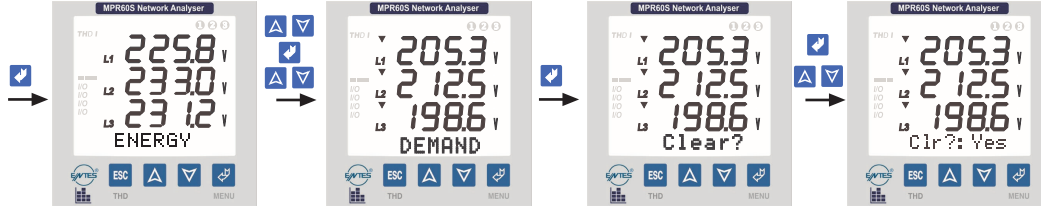

Figure 49: Clearing the min. VLN value

max. Demand IL (Max values of phase currents)

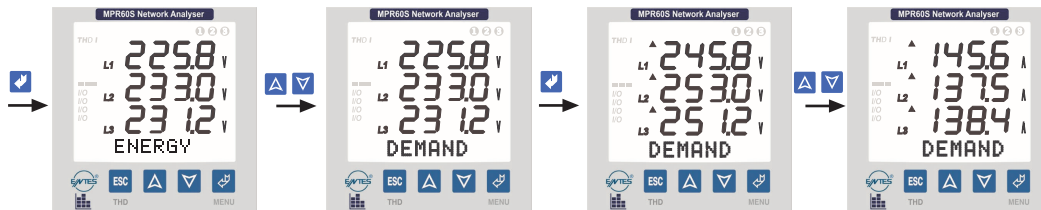

Figure 50: Max. Demand IL value

Clearing the max. Demand IL (Max values of phase currents)

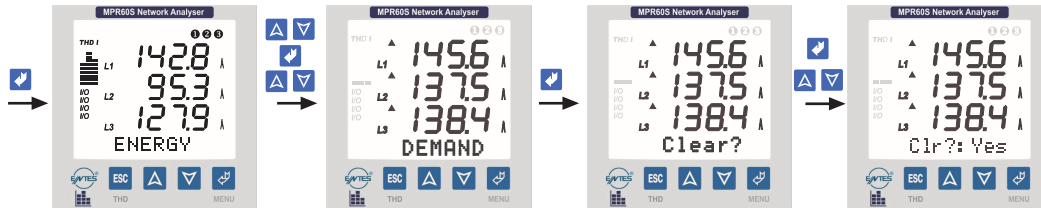

Figure 51: Clearing the max. Demand IL value

min. Demand IL (Min values of phase currents)

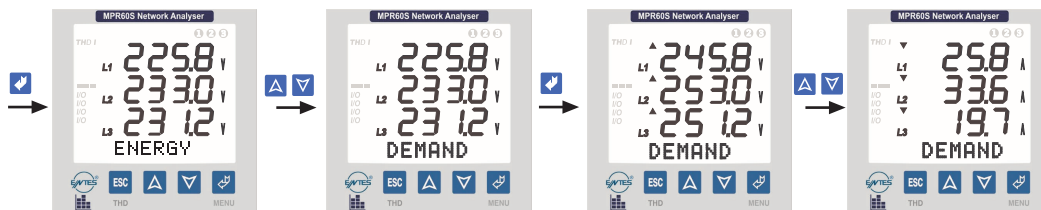

Figure 52: Min. Demand IL value

Clearing the min. Demand IL (Min values of phase currents)

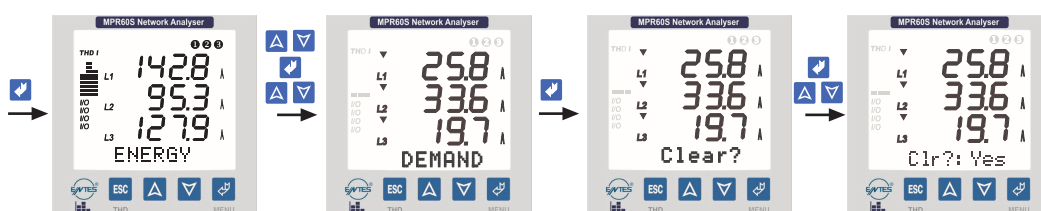

Figure 53: Clearing the min. Demand IL value



Warning :

You may quit all settings any time by **ESC** key.
You must record any change in the settings by menu key.

Demand IL (Demand values of the currents)

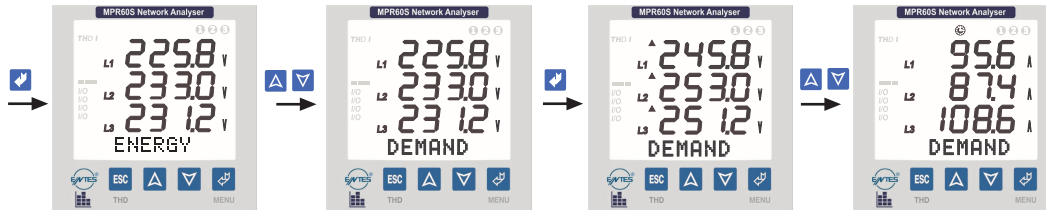

Figure 54: Demand IL

Clearing the Demand IL (Demand values of the currents)

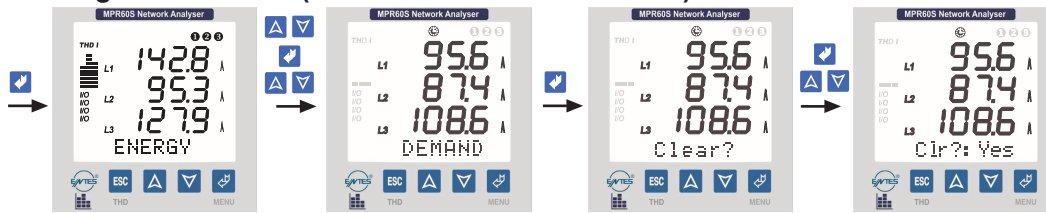

Figure 55: Clearing the demand IL

Demand ΣI, Min. / Max. Demand ΣI (Demand, Min and max demand values of total phase currents)

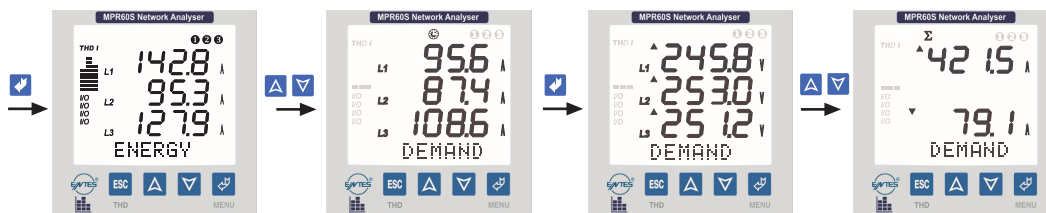

Figure 56: Min. Demand / Demand Max. Σ I

Clearing Demand ΣI, Min. / Max. Demand ΣI (Demand, Min and max demand values of total phase currents)

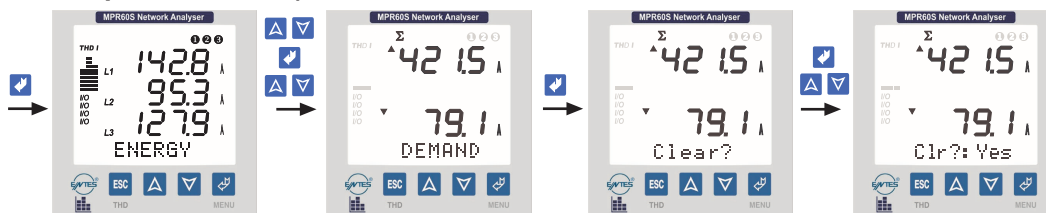

Figure 57: Clearing the Min. Demand / Max. Demand Σ I

Demand Σ Powers (Demand values of total powers)

Active (P), Reactive (Q) and Apparent (S) Powers

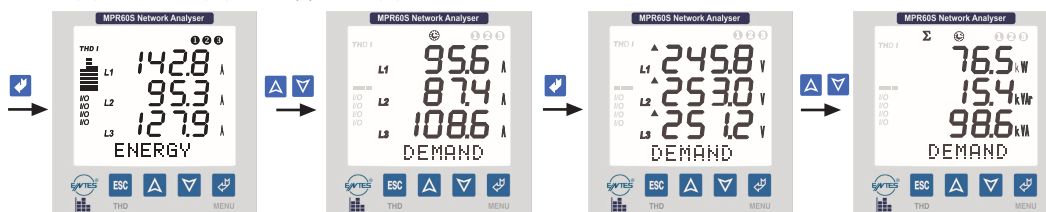

Figure 58: Demand Σ Powers

Clearing the Demand Σ Powers (Demand values of total powers)

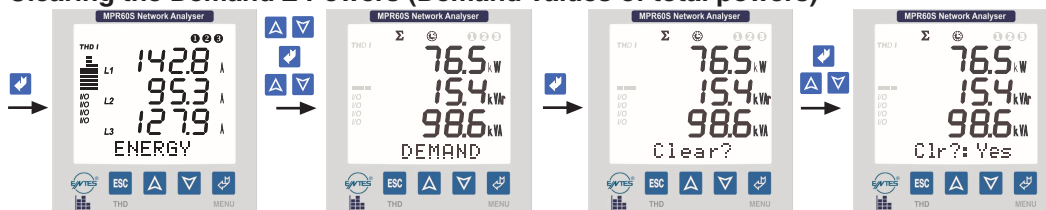

Figure 59: Clearing the Demand Σ Powers

Clearing All Demand values and Min. / Max. Values at Once

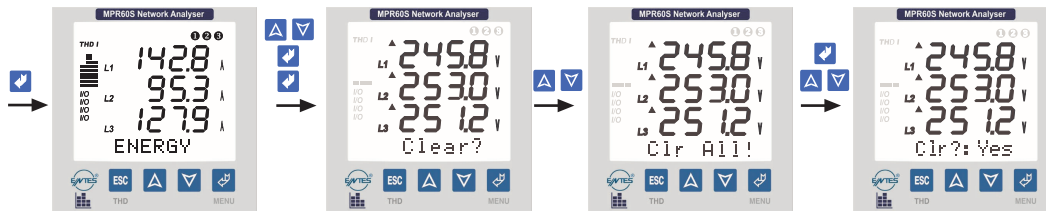

Figure 60: Clearing all demand values and min. / max. values at once

Max. Demand Σ Powers (Max. demand values of total powers)

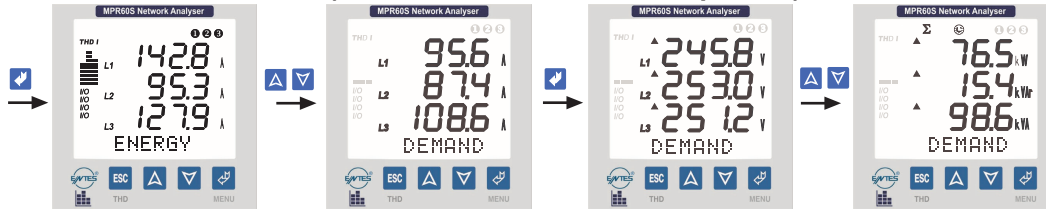

Figure 61: Max. demand value of Σ Powers

Max. Demand Σ Powers (Clearing max. demand values of total powers)

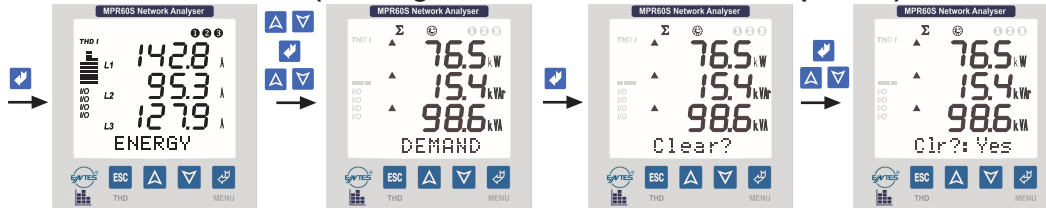

Figure 62: Clearing max. demand values of Σ Powers

Min. Demand Σ Powers (Min. demand values of total powers)

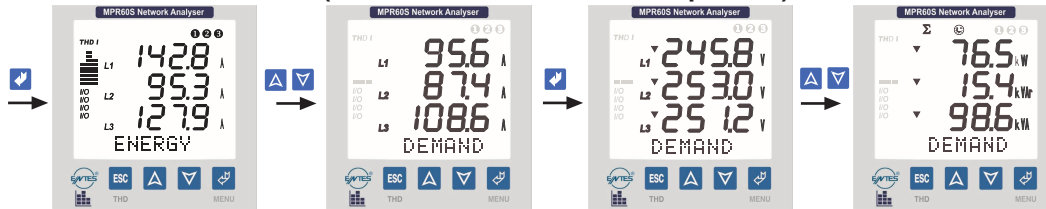

Figure 63: Max. demand value of Σ Powers

Min. Demand Σ Powers (Clearing min. demand values of total powers)

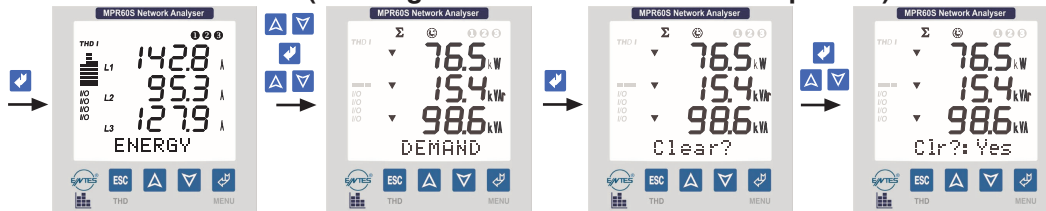

Figure 64: Clearing max. demand values of Σ Powers

Clearing All Demand values and Min. / Max. Values at Once

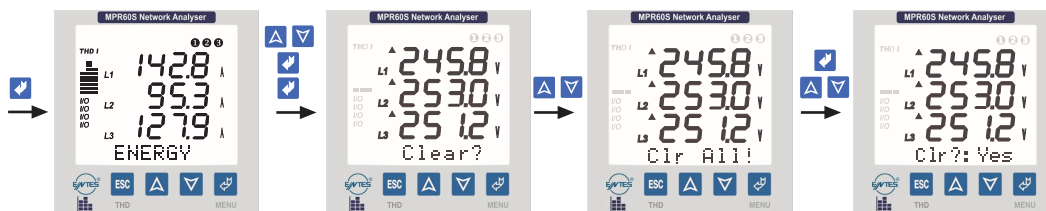

Figure 65: Clearing all demand values and min. / max. values at once

4.13 TIME AND DATE

Time and Date Menus

Time and Date, which are configured from the SETUP menu, are kept in the memory.

Even if the power is switched off, the informations of time and date are saved into the memory.

TIME (Menu for observing the time)

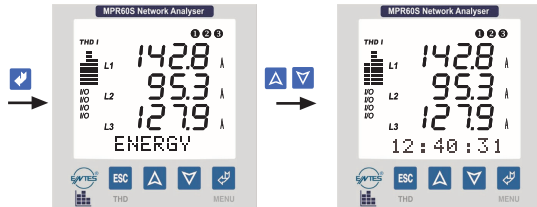

Figure 66: Time

Date (Menu for observing the date)

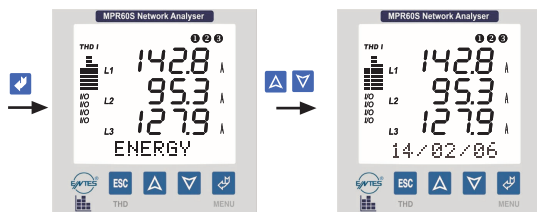

Figure 67: Date

4.14 INFO

INFO

The information about the memory of the device and the manufacturer are seen in this menu.

Information menu has three sub-menus.

Log.Rec..... Eng. Rec.....Producer-Production Information.....

Log. Rec.:

This menu gives us information about the quantity of record lines of the parameters from Pr1 to Pr28 at the top line and indicates the occupied memory.

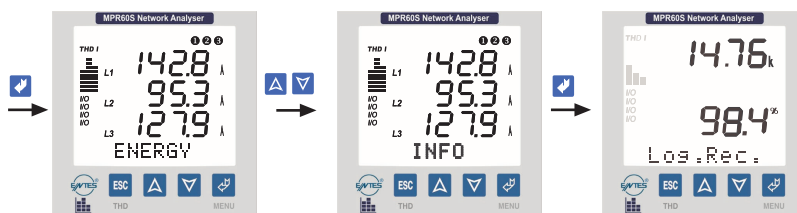

Figure 68: Info

Above, 14760 record lines are memorised and 98,4% of the memory is used.

See page 23 for Datalog Menu

Clearing all recorded parameters from Pr1 to Pr28 in Log. Rec. permanent memory

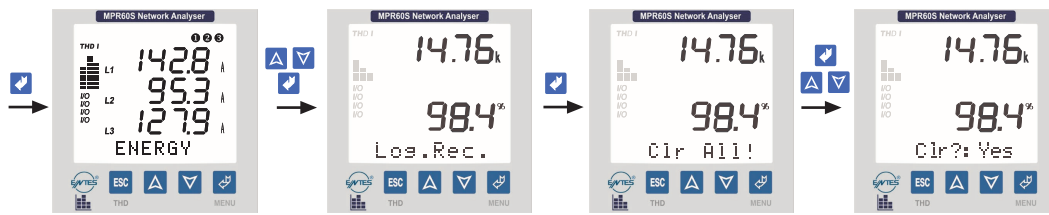

Figure 69: Clearing all recorded parameters

Eng. Rec. (Energy recording)

Device records all energy values (Export Active, Import Active, Inductive Reactive, Capacitive Reactive) in the permanent memory for energy values in every 15 minutes. 1.000 record lines are allocated for energy values. When this area is filled, all energy recordings are cleared to enable further records.



Note: Allocated areas for parameter and energy values are independent from each others. The permanent memory is not affected from power cuts.

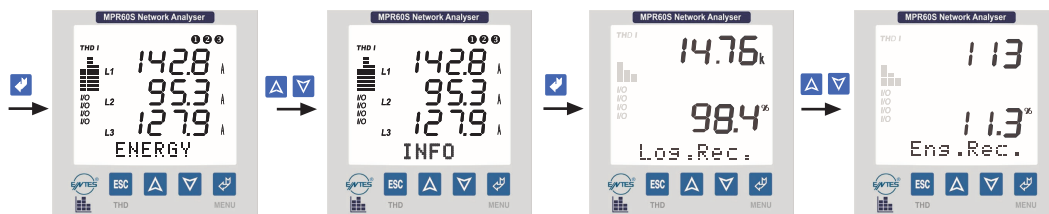

Figure 70: Energy records

Above, 113 record lines are memorised and 11,3% of the memory is used.

Clearing all recorded parameters from Pr1 to Pr28 in the Eng. Rec. permanent memory

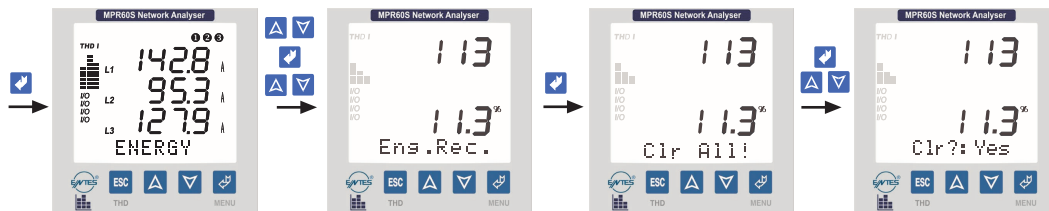

Figure 71: Clearing all recorded parameters in the Eng. Rec. permanent memory



Note : If data records, which are saved in to the permanent memory for every 15 minutes in Eng.Rec. Menu, are cleared, energy values are not affected from this event.

4.15 Manufacturer - Product Information

Information about manufacturer, the version number of the device, company contact information and serial number (8 digit) are on this menu.

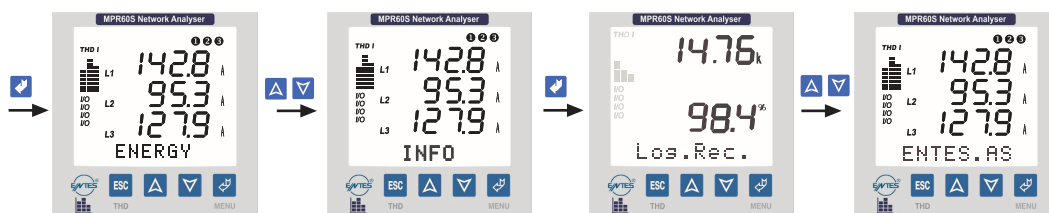

Figure 72: Manufacturer - Product Information

4.16 PASSWORD

User password is set and activated in this menu.

In order to prevent the device's SETUP, DEMAND and ENERGY menus from unauthorized access, it is necessary to set up a 3 digit user password and then activate it.

Set Psw (Menu for setting up a user password)

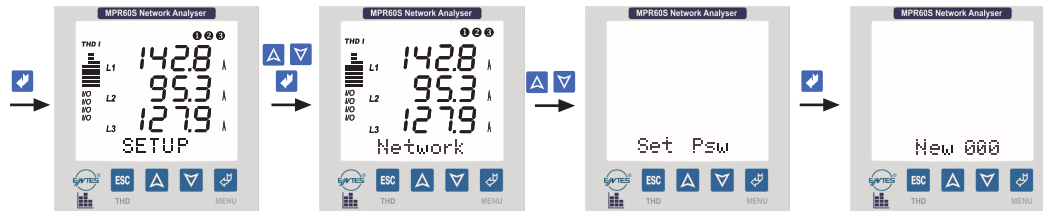

Figure 73: Setting the password

Chg Psw (Menu for changing the user password)

The new password is saved to the SETUP, DEMAND and ENERGY menus.



Figure 74: Changing the password

Main Password : 236

4.17 PARAMETER TABLE

The parameters, that can be set, are marked with an * symbol in the parameter table.

* $V_{L1, L2, L3}$	(Phase Voltage)
* $V_{L12, L23, L31}$	(Phase-Phase Voltage)
* V_N^L (Average)	(Total Phase Voltage Average)
* V_L^L (Average)	(Total Phase-Phase Voltages Average)
*Freq.Hz	(Frequency)
* $I_{L1, L2, L3}$	(Phase Currents)
* ΣI	(Total Phase Currents)
* $P_{L1, L2, L3}(W)$	(Active Power)
* $Q_{L1, L2, L3}(VAr)$	(Reactive Power)
* $S_{L1, L2, L3}(VA)$	(Apparent Power)
* ΣP . (W)	(Total Active Power)
* ΣQ . (VAr)	(Total Reactive Power)
* ΣS . (VA)	(Total Apparent Power)
* $\cos\phi_{L1, L2, L3}$	(Displacement Power Factor)
* $PF_{L1, L2, L3}$	(Power Factor)
ΣP . F	(Total Power Factor)
Exp.(KWh)	(Export Active Energy)
Imp.(KWh)	(Import Active Energy)
Ind.(KVarh)	(Inductive Reactive Energy)
Cap.(KVarh)	(Capacitive Reactive Energy)
* $H-V_{L1, L2, L3}$	(Harmonic Values for Voltages)
* $H-I_{L1, L2, L3}$	(Harmonic Values for Currents)
*Max.VLN	(Maksimum Phase Voltage)
*Min. VLN	(Minimum Phase Voltage)
*Max. Demand I_L	(Max. Demand of Phase Currents)
*Min. Demand I_L	(Min. Demand of Phase Currents)
*Max. Demand ΣI	(Max. Demand of Total Phase Currents)
*Min. Demand ΣI	(Min. Demand of TotalPhase Currents)
*Demand I_L	(Demand of Phase Currents)
*Demand ΣI_L	(Demand of Total Phase Currents)
*Demand ΣW	(Demand of Total Active Powers)
*Demand ΣVAr	(Demand of Total Reactive Powers)
*Demand ΣVA	(Demand of Total Apparent Powers)
Hr.	(Hour)
Min.	(Minute)
Sec.	(Second)
Day	(Day)
Mo.	(Month)
Year	(Year)
CTR	(Current Transformerr Ratio)
VTR	(Voltage Transformerr Ratio)
IOS	(Relay Position)
* I_n	(Neutral Current)
Max. Demand ΣW	(Max. Demand of Total Active Powers)
Max. Demand ΣVAr	(Max. Demand of Total Reactive Powers)
Max. Demand ΣVA	(Max. Demand of Total Apparent Powers)
Min. Demand ΣW	(Min. Demand of Total Active Powers)
Min. Demand ΣVAr	(Min. Demand of Total Reactive Powers)
Min. Demand ΣVA	(Min. Demand of Total Apparent Powers)

4.18 FORMULAS

RMS Values for Voltages	$V_{rms} = \sqrt{\frac{1}{N} \sum_{i=0}^N v_i^2}$	RMS Values for Currents	$I_{rms} = \sqrt{\frac{1}{N} \sum_{i=0}^N i_i^2}$
Total Active Power	$P = \frac{1}{N} \sum_{i=0}^N p_i$	Total Reactive Power	$Q = \frac{1}{N} \sum_{i=0}^N q_i$
Apparent Power	$\Sigma S = \sqrt{\Sigma P^2 + \Sigma Q^2}$	Total Power Factor	$\Sigma P.F. = \frac{\Sigma P}{\Sigma S}$
Total Harmonic Distortion for Voltages	$V_{THD} \% = \frac{\sqrt{\sum_{i=2}^{31} V_i^2}}{V_1} \times 100$		
Total Harmonic Distortion for Currents	$I_{THD} \% = \frac{\sqrt{\sum_{i=2}^{31} I_i^2}}{I_1} \times 100$		

4.19 Current Analog Output (0/4-20mA) (Only for MPR60S-40/41)

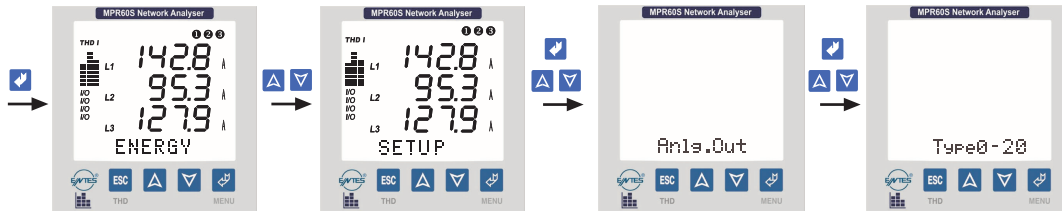

In device, this feature gives the possibility that observing the measured values by other devices with converting these values in to 0-20 mA or 4-20 mA current data. The below parameters can be set as analog output in device.

The below parameters can be set as analog output :

VL1, L2, L3 (V)	(Phase Voltage)	PL1, L2, L3 (W)	(Active Power)
VL12, L23, L31 (V)	(Phase-Phase Voltage)	QL1, L2, L3 (VAR)	(Reactive Power)
V _h (Average)	(Average of the total phase voltages)	SL1, L2, L3 (VA)	(Apparent Power)
V _t (Average)	(Average of the total phase-phase voltages)	ΣI _t (A)	(Total Phase Currents)
Frequency (Hz)	(Frequency)	ΣP _t (W)	(Total Active Power)
IL1, L2, L3 (A)	(Phase Currents)	ΣQ _t (VAR)	(Total Reactive Power)
THD %VL1, L2, L3	(Total Harmonic Values for Voltages)	ΣS _t (VA)	(Total Apparent Power)
THD %I L1, L2, L3	(Total Harmonic Values for Currents)		

For example

Below settings should be fulfilled as like :

Type : 0-20 mA
 Prm (Parameter) : VL1
 Lo (Low value) : 0V
 Hi (High value) : 300 V

After above settings are completed;
 Analog current output's value will be 0 mA when VL1 value is 0 V,
 Analog current output's value will be 20 mA when VL1 value is 300 V.
 When VL1 is 220 V analog voltage output value will be;

$$I_{out} = \frac{(20-0) \times (220-0)}{(300-0)} = 14,67 \text{mA}$$

For example

Below settings should be fulfilled as like :

Type : 0-20 mA
 Prm (Parameter) : PL1
 Lo (Low value) : -650 W
 Hi (High value) : 350 W

After above settings are completed;
 Analog current output's value will be 0 mA when PL1 value is -650 W,
 Analog current output's value will be 20 mA when PL1 value is 350 W
 When PL1 is -300 W analog voltage output value will be;

$$I_{out} = \frac{(20-0) \times [-300 - (-650)]}{[350 - (-650)]} = 7 \text{ mA}$$

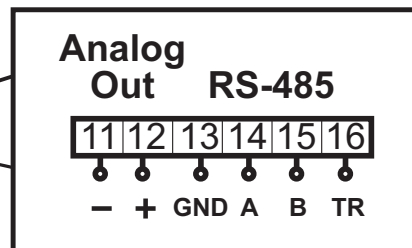
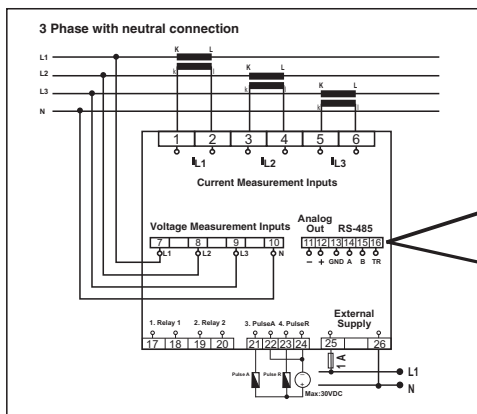
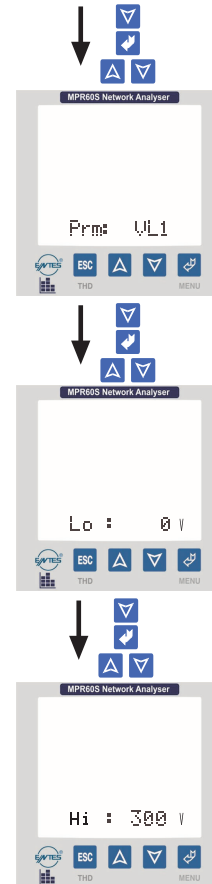

4.20 Voltage Analog Output (0/2-10V) (Only for MPR60S-20/21)

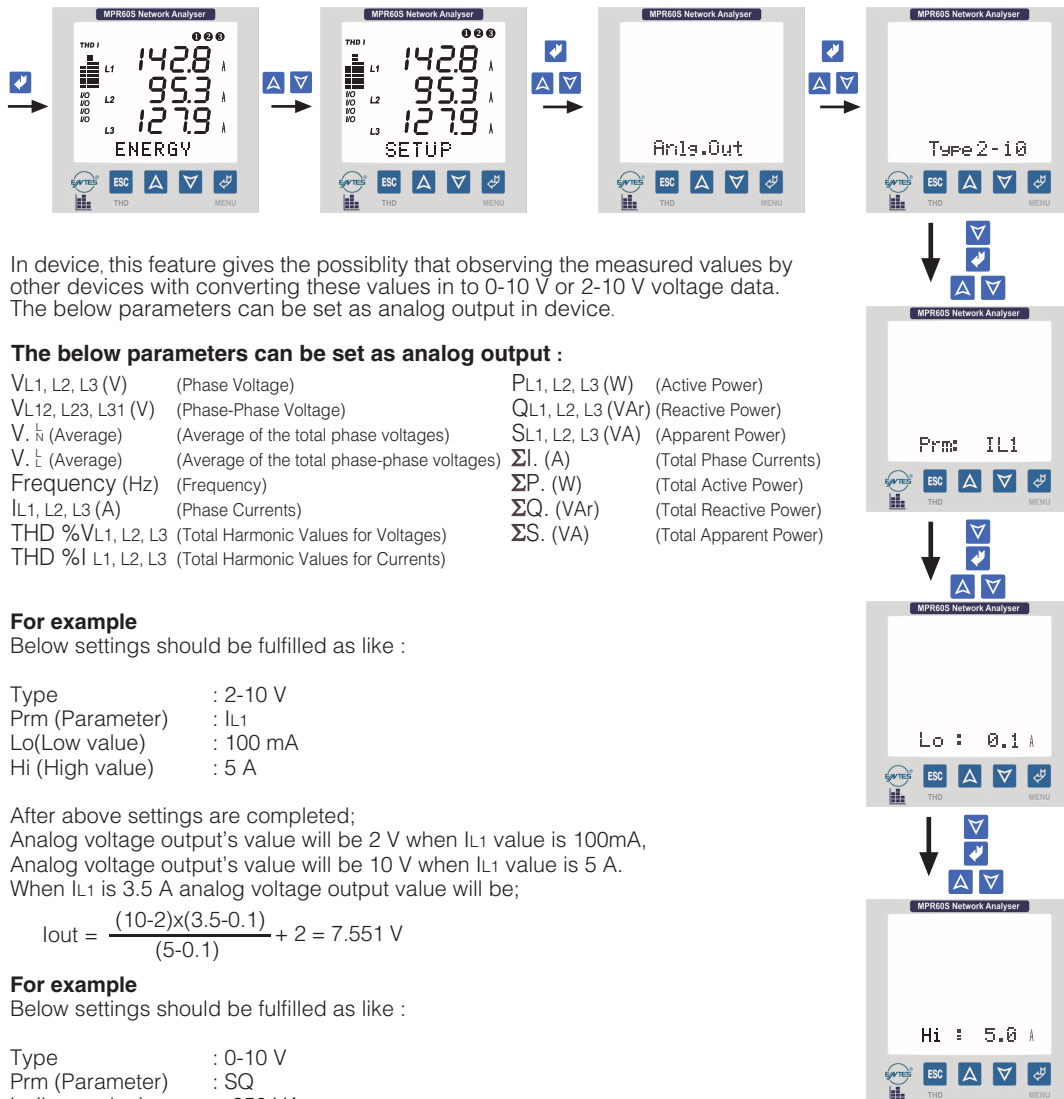

In device, this feature gives the possibility that observing the measured values by other devices with converting these values in to 0-10 V or 2-10 V voltage data. The below parameters can be set as analog output in device.

The below parameters can be set as analog output :

VL1, L2, L3 (V)	(Phase Voltage)	PL1, L2, L3 (W)	(Active Power)
VL12, L23, L31 (V)	(Phase-Phase Voltage)	QL1, L2, L3 (VAR)	(Reactive Power)
V. \bar{n} (Average)	(Average of the total phase voltages)	SL1, L2, L3 (VA)	(Apparent Power)
V. \bar{t} (Average)	(Average of the total phase-phase voltages)	Σ I. (A)	(Total Phase Currents)
Frequency (Hz)	(Frequency)	Σ P. (W)	(Total Active Power)
IL1, L2, L3 (A)	(Phase Currents)	Σ Q. (VAR)	(Total Reactive Power)
THD %VL1, L2, L3	(Total Harmonic Values for Voltages)	Σ S. (VA)	(Total Apparent Power)
THD %I L1, L2, L3	(Total Harmonic Values for Currents)		

For example

Below settings should be fulfilled as like :

Type : 2-10 V
 Prm (Parameter) : IL1
 Lo(Low value) : 100 mA
 Hi (High value) : 5 A

After above settings are completed;
 Analog voltage output's value will be 2 V when IL1 value is 100mA,
 Analog voltage output's value will be 10 V when IL1 value is 5 A.
 When IL1 is 3.5 A analog voltage output value will be;

$$I_{out} = \frac{(10-2) \times (3.5-0.1)}{(5-0.1)} + 2 = 7.551 \text{ V}$$

For example

Below settings should be fulfilled as like :

Type : 0-10 V
 Prm (Parameter) : SQ
 Lo(Low value) : -250 VAR
 Hi (High value) : 750 VAR

After above settings are completed;
 Analog voltage output's value will be 0 V when SQ value is -250 VAR,
 Analog voltage output's value will be 10 V when SQ value is 750 VAR.
 When SQ is 400 VAR analog voltage output value will be;

$$I_{out} = \frac{(10-0) \times [400 - (-250)]}{[750 - (-250)]} = 6,5 \text{ V}$$

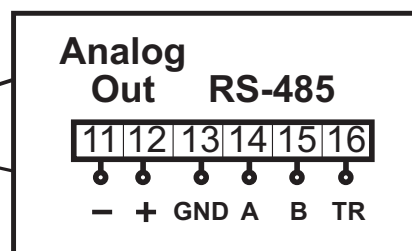
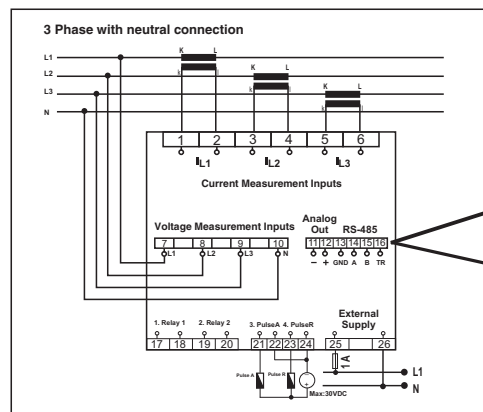

4.21 FACTORY SETTINGS

Network

CT (Current transformer) : 10
 VT (Voltage transformer) : 1.0
 Net (System Connection) : 3P4W
 Eng (Energy) : Tot.
 E.Unit (Energy Unit) : k

Display

Loop (Loop duration) : No
 Cont (Contrast) : 6
 BL. (Backlight) : Auto

RS-485

Addr (Address) : 1
 Bd (Baud rate value) : 9600 bps
 Prt (Parity) : None

Datalog

Per (Period) : 900 sec.
 Event : No
 Pr1(Parameter 1) : VL1
 Pr2(Parameter 2) : VL2
 Pr3(Parameter 3) : VL3
 Pr4(Parameter 4) : IL1
 Pr5(Parameter 5) : IL2
 Pr6(Parameter 6) : IL3
 Pr7(Parameter 7) : Σ
 Pr8(Parameter 8) : P1
 Pr9(Parameter 9) : P2
 Pr10(Parameter 10) : P3
 Pr11(Parameter 11) : Q1
 Pr12(Parameter 12) : Q2
 Pr13(Parameter 13) : Q3
 Pr14(Parameter 14) : S1
 Pr15(Parameter 15) : S2
 Pr16(Parameter 16) : S3
 Pr17(Parameter 17) : PF1
 Pr18(Parameter 18) : PF2
 Pr19(Parameter 19) : PF3
 Pr20(Parameter 20) : Cos1
 Pr21(Parameter 21) : Cos2
 Pr22(Parameter 22) : Cos3
 Pr23(Parameter 23) : V12
 Pr24(Parameter 24) : V23
 Pr25(Parameter 25) : V31
 Pr26(Parameter 26) : $V_{\frac{1}{N}}$
 Pr27(Parameter 27) : $V_{\frac{1}{L}}$
 Pr28 (Parameter 28) : Freq.

1.Relay1

Cfg : Digital Output
 Pr1,Pr2,Pr3 (Parameters) : Off
 Hi1,Hi2,Hi3 (High) : ----
 Lo1,Lo2,Lo3 (Low) : ----
 Hs1,Hs2,Hs3 (Hysterisis) : ----
 Dly1,Dly2,Dly3 (Delay) : ----

2.Relay 2

Cfg : Digital Output
 Pr1,Pr2,Pr3 (Parameters) : Off
 Hi1,Hi2,Hi3 (High) : ----
 Lo1,Lo2,Lo3 (Low) : ----
 Hs1,Hs2,Hs3 (Hysterisis) : ----
 Dly1,Dly2,Dly3 (Delay) : ----

3. Pulse A (only for MPR60S/MPR60S-21/41)

Prm(Energy value to set for 1 pulse) : 1 kWh
 Dur (Pulse width) : 250 msec.

4. Pulse R (only for MPR60S/MPR60S-21/41)

Prm(Energy value to set for 1 pulse) : 1 kVArh
 Dur (Pulse width) : 250 msec.

3. Input-1 (only for MPR60S-10/20/21)

Fn : Real Time

4. Input-2 (only for MPR60S-10/20/21)

Fn : Real Time

Current Analog Output (only for MPR60S-40/41)

Type : 0-20 mA
 Prm (Parameter) : None
 Lo (Low) : -
 Hi (High) : -

Voltage Analog Output (only for MPR60S-20/21)

Type : 0-10 V
 Prm (Parameter) : None
 Lo (Low) : -
 Hi (High) : -

Password

Set Psw (Setting up the password) : None (000)

4.22 TECHNICAL DATA

Operating Voltage (Un)	: Please look behind the device.
Frequency	: 50 / 60 Hz
Power Consumption	: < 6 VA
Burden	: < 1 VA (Current Burden) : < 0.5 VA (Voltage Burden)
Measurement Input	
Voltage	: 1,0 - 300,0 V AC (L-N) : 2,0 - 500,0 V AC (L-L)
Current	: 0,005 - 5.5 A
Measurement Ranges	
Voltage	: 1,0 V - 400,0 kV
Current	: 0,005 - 10.000 A
Frequency	: 45,0 - 65,0 Hz
Power	: 0 - 4000 M (W, VAr, VA)
Energy	: 0 - 99 999 999 kWh, kVArh or MWh, MVAh
Measurement Category	: CAT III
Accuracy	
Voltage, Current	: 0.5%±2digit
Active Power	: 1%±2digit
Reactive, Apparent Power	: 2%±2digit
Voltage Transformer Ratio	: 1,0...4000,0
Current Transformer Ratio	: 1...5000
Connection Type	: 3P-4W, 3P-3W, ARON
Relay Outputs (2 pcs.)	: 2 NO, 5A, 1250 VA
Demand Time	: 15 min.
Communication Interface	: MODBUS RTU (RS-485)
Baud Rate	: 1200 - 38400 bps
Address	: 1 - 247
Parity	: None, Even, Odd Parity
Data Logging	
Parameters	: Chosen 28 parameters with date and time
Record Size	: 15000 record lines
Log Duration (time interval between 2 records)	: No, 5 - 32.000 seconds
Energy Record	: 1000 record lines (1 record in every 15 minutes)
Event	: Yes, No
Memory	: 1 MB Internal Memory
Digital Inputs (2 pcs.)	
Functions	: Real Time / Latch
Input Pulse Width	: Min. 50 ms
Operation Voltage	: 5...24 V DC, max. 30 V DC
Energy Pulse Outputs (2 pcs.)	
Switch Period	: Min. 1 sec.
Pulse Width	: 100-2500 ms
Operation Current	: Max. 50 mA
Operation Voltage	: 5-24 V DC max. 30 V DC
Analog Voltage Output	: 0-10 V or 2-10 V
Load Resistance	: ≥5 kΩ
Response Perriod	: 1 sec.
Analog Current Output	: 0-20 mA or 4-20 mA
Load Resistance	: ≤500 Ω
Response Perriod	: 1 sec.
Real Time Clock	: hh : mm : ss ; dd / mm / yy
Ambient Temperature	: -5°C ; +50°C
Display	: 3,6" LCD with Backlight
Dimensions	: PR19
Equipment Protection Class	: Double Insulation-Class II (□)
Box Protection Class	: IP 40
Terminal Block Protection Class	: IP 00
Box Material	: Non-flammable
Installation	: Flush mounting with rear terminals
Wire Thickness for Voltage Connection	: 2,5 mm ²
Wire Thickness for Current Connection	: 4,0 mm ²
Wire Thickness for Pulse or	
Digital Input Connection	: 1,5 mm ²
RS-485 Connection	: Category 5 Cable (Shielded Twisted Pair)
Weight	: 0.75 kg
Installation Category	: Class II
Type	: PR 19
Package Dimensions	: 280x280x265 mm
Package Weight	: 6 kg
Pcs per Package	: 8 pcs

5. Standarts and Explanations

EN 61000-6-2 : Electromagnetic compatibility (EMC). Generic standards. Immunity for industrial environments.

EN 61000-6-4 : Electromagnetic compatibility (EMC). Generic standards. Emission standard for industrial environments.

EN 55016-2-1 : Specification for radio disturbance and immunity measuring apparatus and methods. Methods of measurement of disturbances and immunity. Conducted disturbance measurements.

EN 55016-2-3 : Specification for radio disturbance and immunity measuring apparatus and methods. Methods of measurement of disturbances and immunity. Radiated disturbance measurements.

EN 55011 : Limits and methods of measurement of radio disturbance characteristics of industrial, scientific and medical (ISM) radio-frequency equipment.

EN 61000-3-2 : Electromagnetic compatibility (EMC). Limits for harmonic current emissions (equipment input current < 16A per phase)

EN 61000-3-3 : Electromagnetic compatibility (EMC) - Part 3-3: Limits - Limitation of voltage changes, voltage fluctuations and flicker in public low-voltage supply systems, for equipment with rated current = 16 A per phase and not subject to conditional connection.

EN 61010-1 : Safety requirements for electrical equipment for measurement, control, and laboratory use - Part 1: General requirements.

EN 61000-4-2 : Electrostatic discharge immunity test.

EN 61000-4-3 : Radiated RF electromagnetic field immunity test.

EN 61000-4-4 : Electrical fast transient/burst immunity test.

EN 61000-4-5 : Surge immunity test.

EN 61000-4-6 : Immunity to RF conducted disturbances.

EN 61000-4-8 : Power frequency magnetic field immunity test.

EN 61000-4-11 : Voltage dips, short interruptions and voltage variations immunity test.

MPR60S MENU MAP

ON
↓

INSTANT VALUES

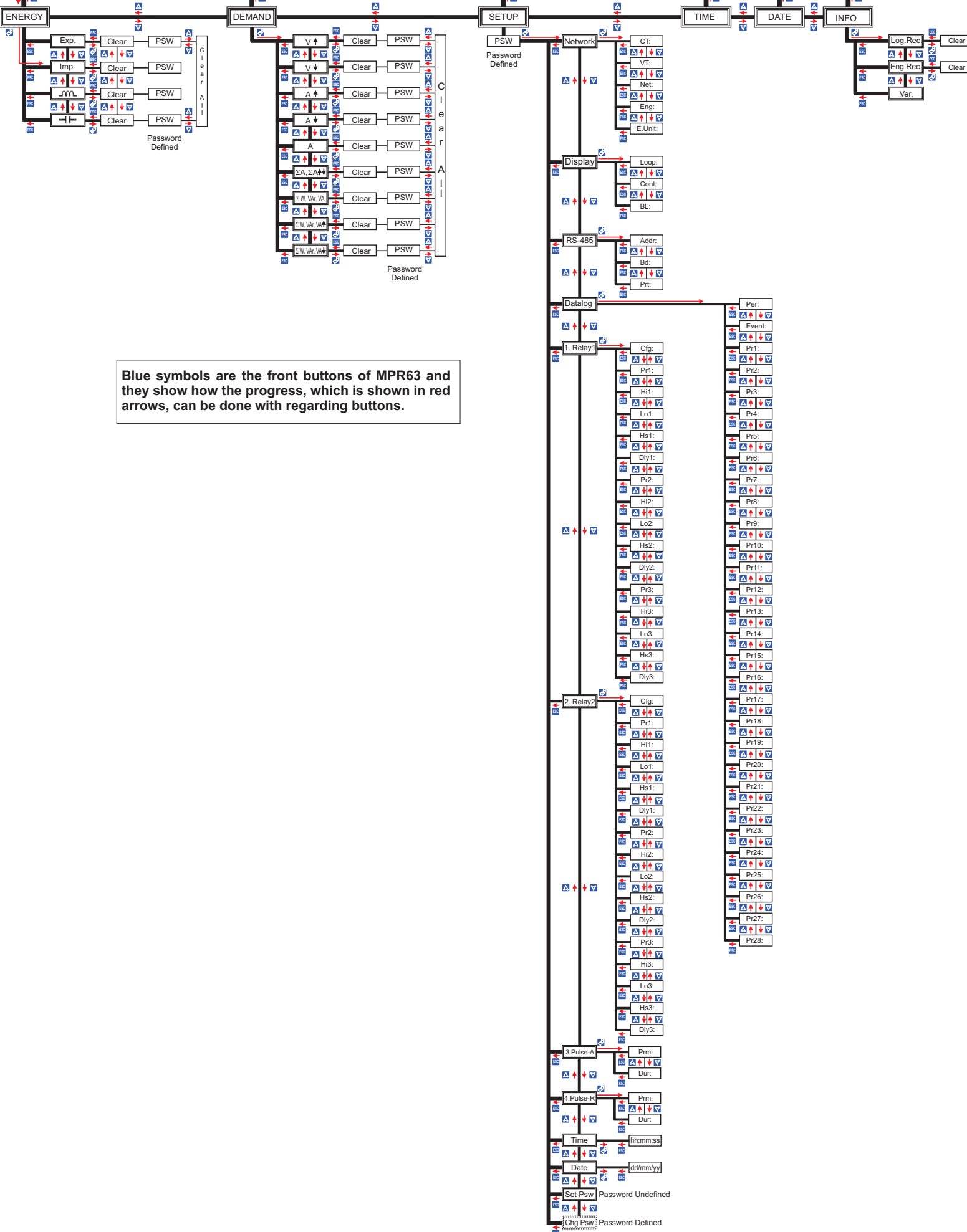
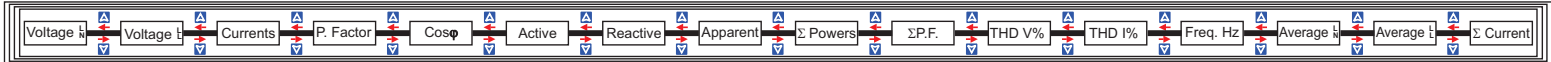

Blue symbols are the front buttons of MPR63 and they show how the progress, which is shown in red arrows, can be done with regarding buttons.

MPR60S-10 MENU MAP



INSTANT VALUES

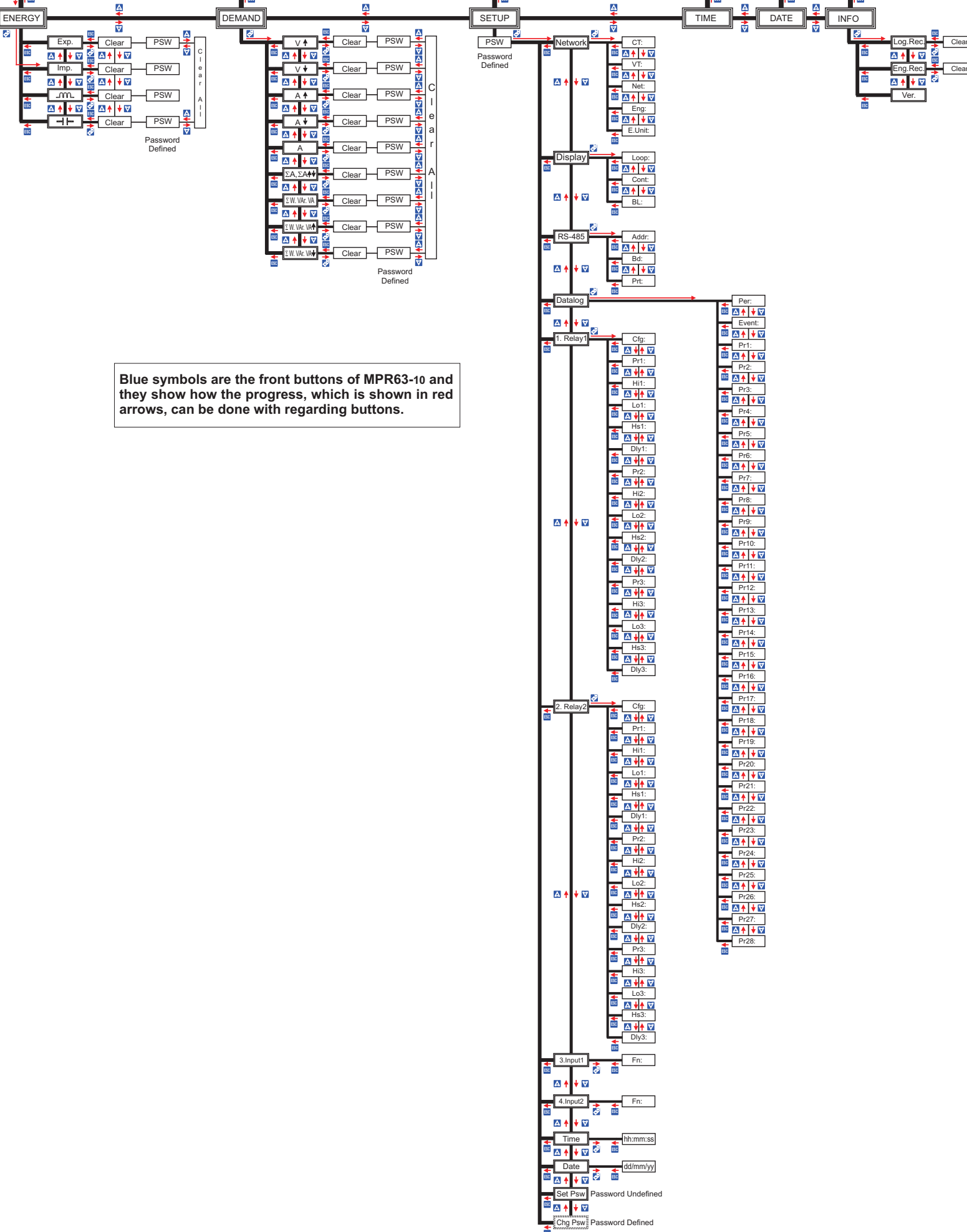
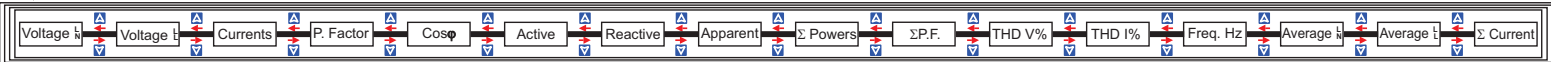

Blue symbols are the front buttons of MPR63-10 and they show how the progress, which is shown in red arrows, can be done with regarding buttons.

MPR60S-20 MENU MAP

INSTANT VALUES

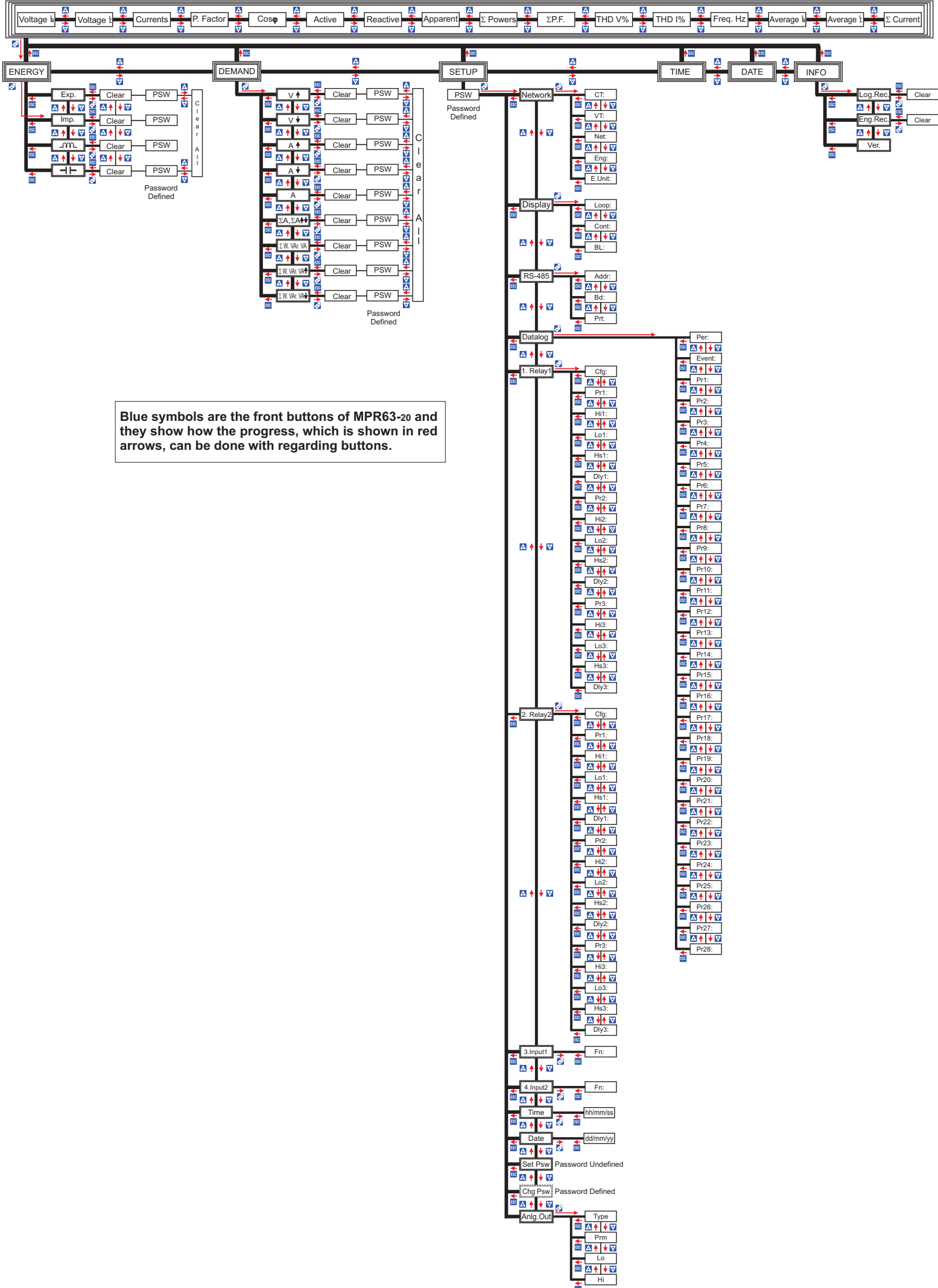

MPR60S-21 MENU MAP

INSTANT VALUES

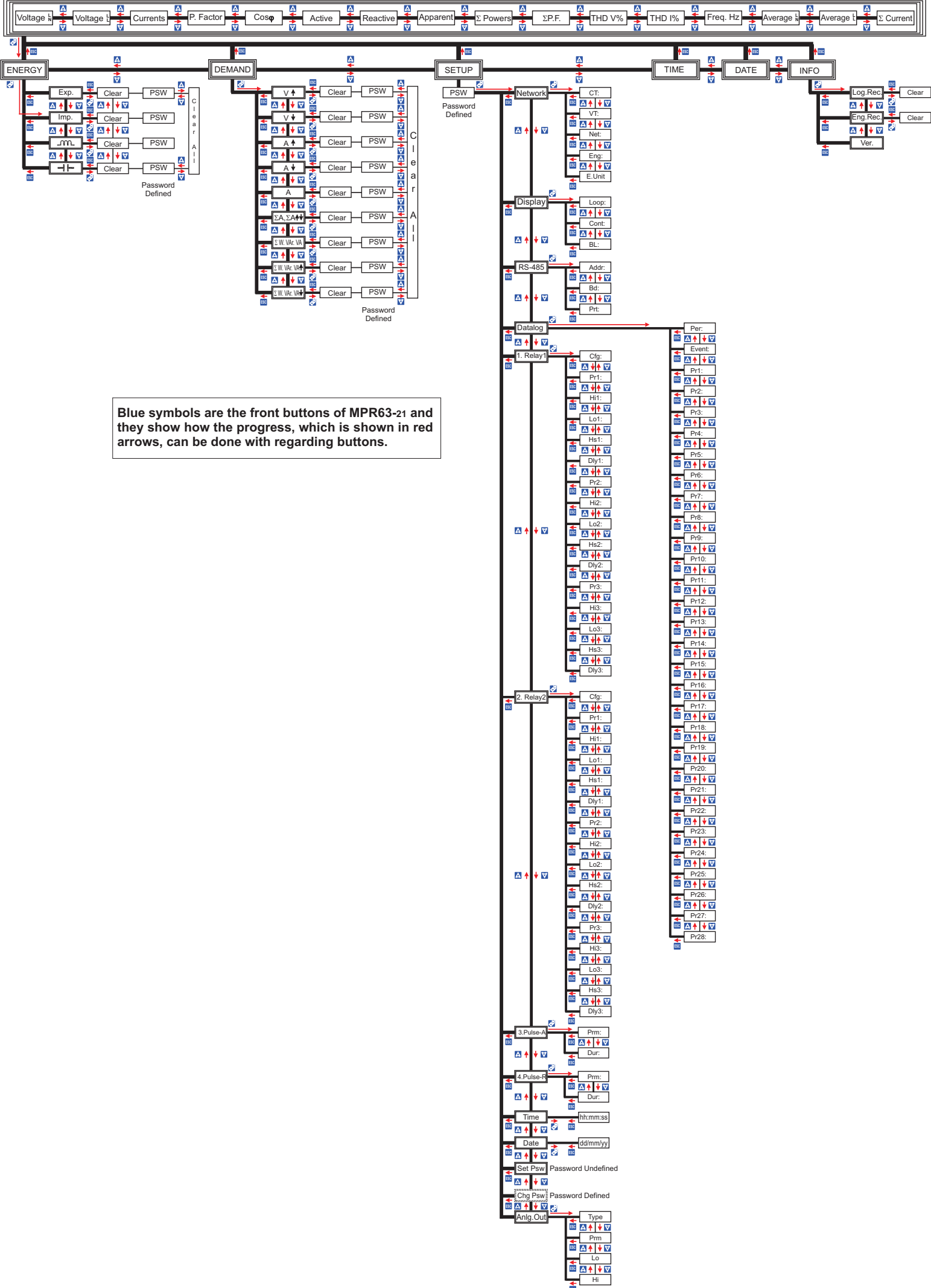

Blue symbols are the front buttons of MPR63-21 and they show how the progress, which is shown in red arrows, can be done with regarding buttons.

MPR60S-40 MENU MAP

INSTANT VALUES

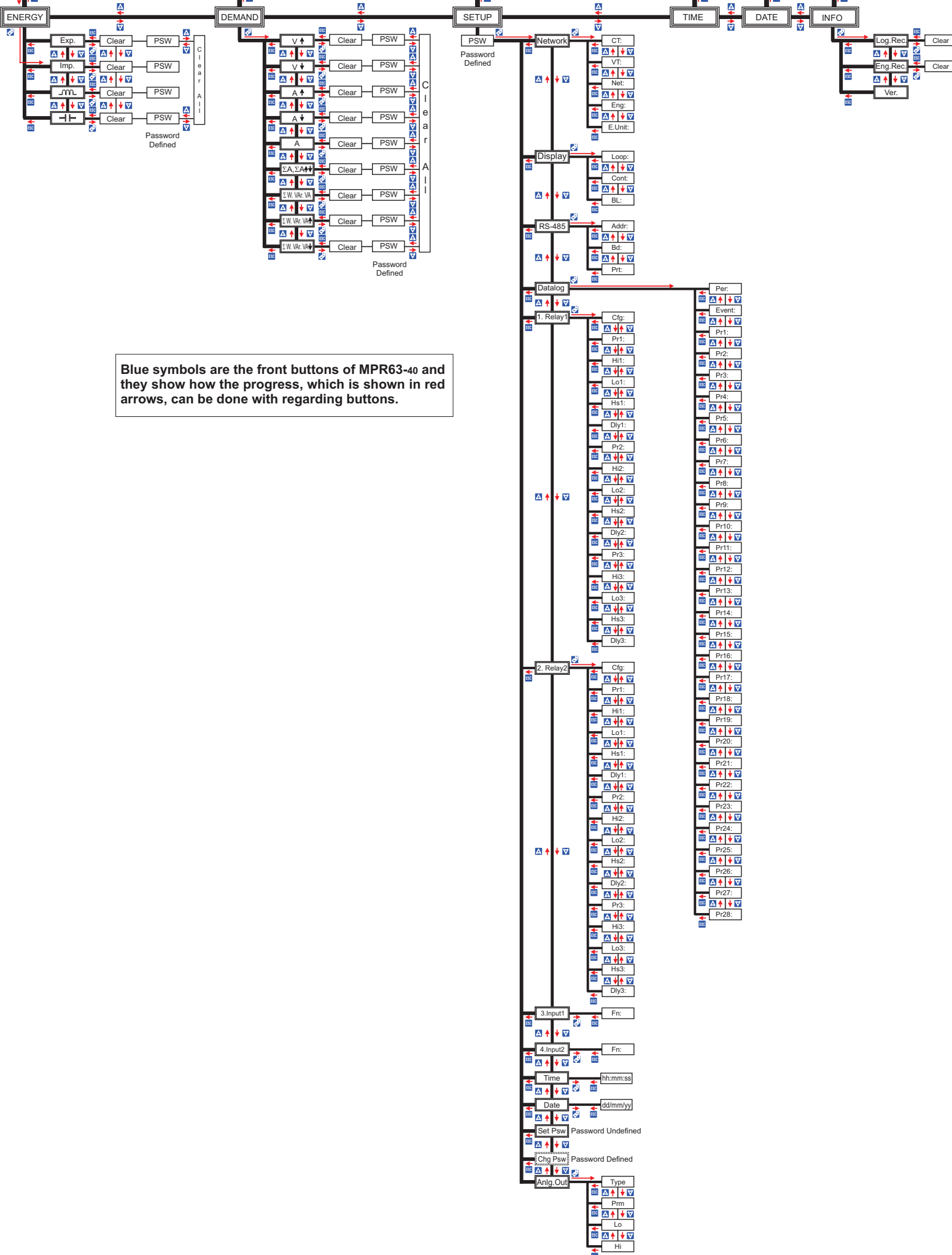
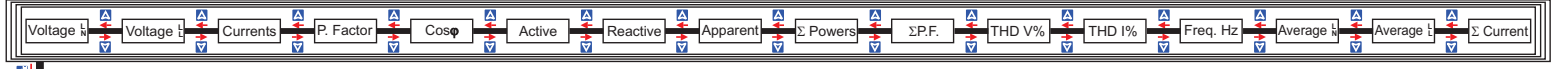

Blue symbols are the front buttons of MPR63-40 and they show how the progress, which is shown in red arrows, can be done with regarding buttons.

MPR60S-41 MENU MAP

INSTANT VALUES

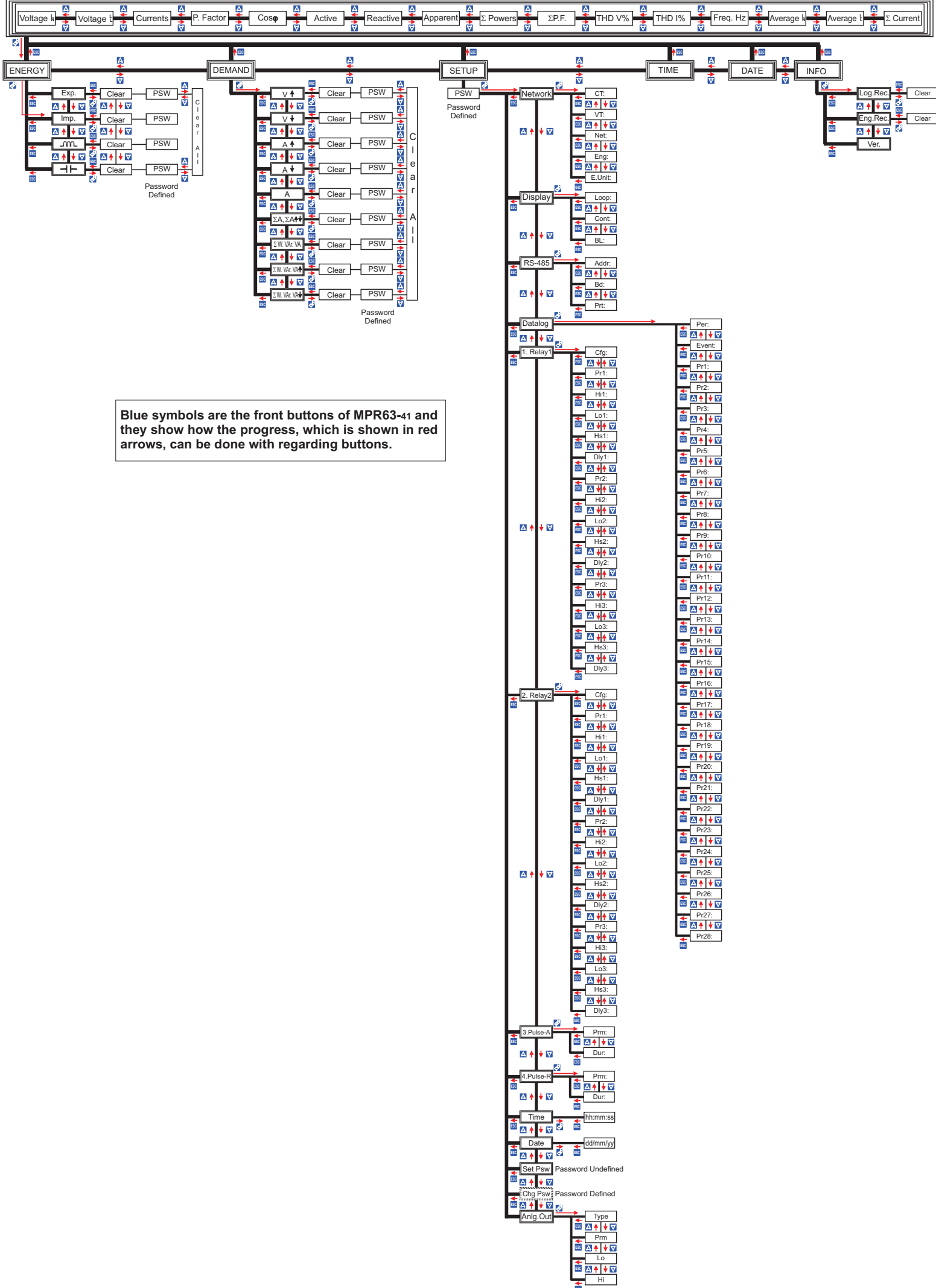

Blue symbols are the front buttons of MPR63-41 and they show how the progress, which is shown in red arrows, can be done with regarding buttons.